

(PL) Instrukcja montażu

(CZ) Návod k montáži

(D) Montageanleitung

(GB) Assembly instruction

(F) Model d'emploi

(HU) Szerelési útmutató

(I) Istruzione di montaggio

(NL) Handleiding voor de montage

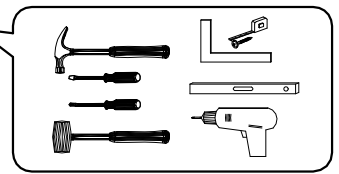

(RU) Инструкция по монтажу

(RO) Instrucțiuni de montare



(SK) Návod k montáži

(TR) Montaj talimatı

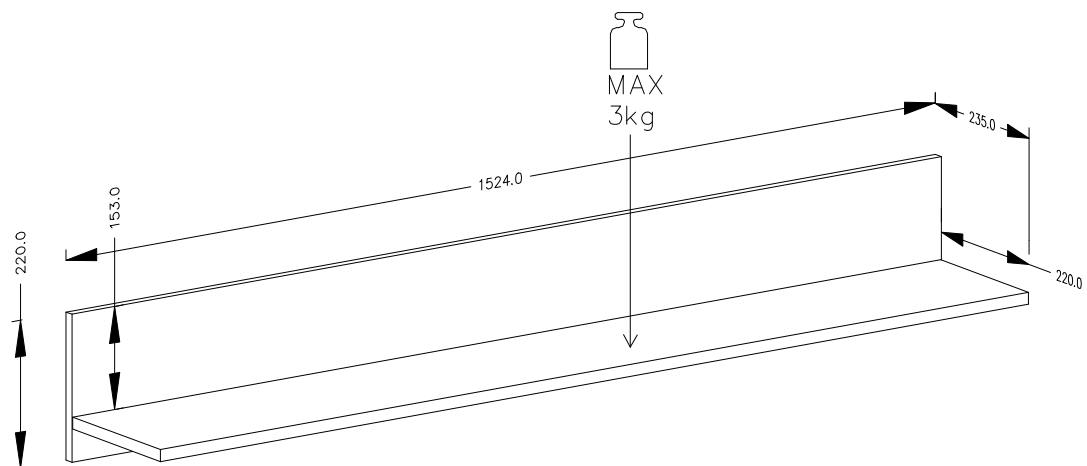
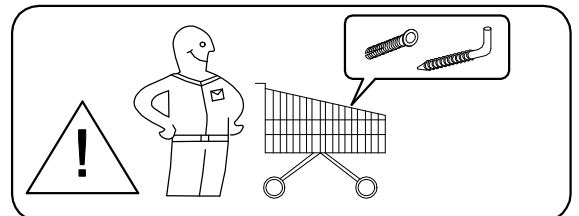
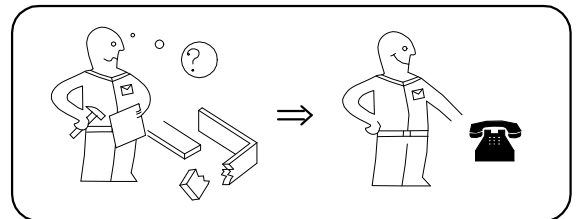
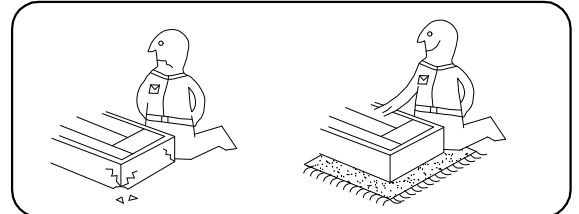

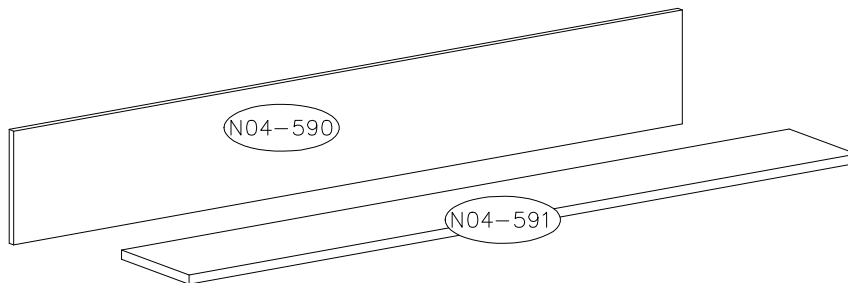
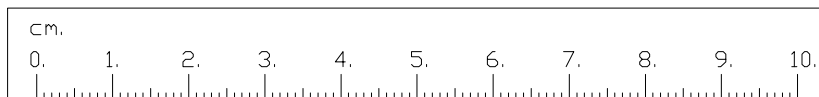
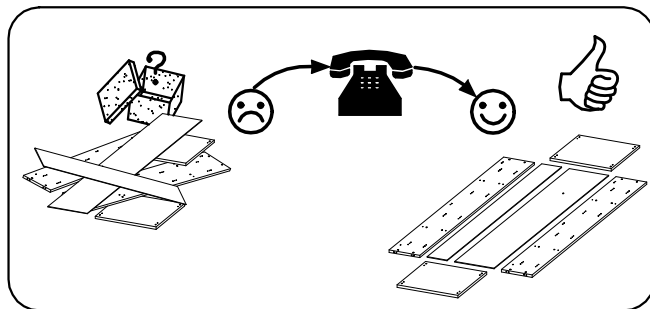
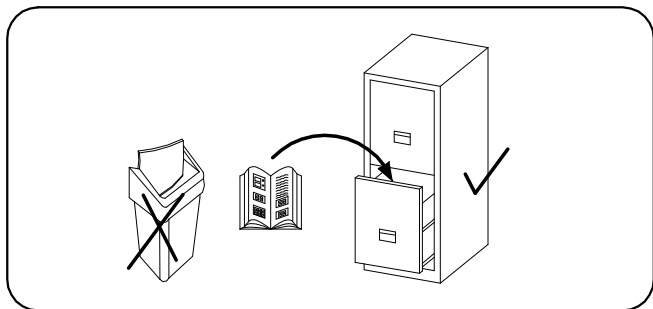
⚠ <b>Uwaga • Upozornění • Achtung • Attention • Caution • Figyelem</b> <b>Attenzione • Opgelet • Внимание • Atenție • Upozornenie • Dikkat</b> ⚠	
PL	Czyszczenie należy wykonać wyłącznie za pomocą ściereczki lub lekko nawilżonego ręcznika. Nie stosować środków czyszczących do szorowania.
CZ	Čistění je nutné vykonávat výhradně pomocí utěrky nebo lehce navlhčeného ručníku. Nepoužívejte čisticí prostředky obsahující abrazivní částice.
D	Bitte nur mit einem Staubtuch oder leicht feuchtem Lappen reinigen. Keine scheuernden Putzmittel verwenden.
GB	Please only clean with a duster or a damp cloth. Do not use any abrasive cleaners.
F	Le nettoyage se fait uniquement à l'aide d'un torchon ou d'une serviette légèrement mouillée.
HU	A tisztítás kizárólag törülköruha vagy enyhén nedvestett törölköző segítségével végezhető. Súroló hatású tisztítószereket nem szabad használni.
I	Pulire esclusivamente con un panno o un asciugamano umido.
NL	Reinig alleen met een stofdoek of een lichtjes vochtige doek. Gebruik geen schurende poetsmiddelen.
RU	Очищайте от пыли тряпкой или слегка влажной ветошью. Не допускаются применение чистящих средств, не пред-назначенных для ухода за мебелью.
RO	Curățarea trebuie efectuată numai cu o cârpă sau cu un prosop ușor umezit. Nu utilizați agenți de curățare abrazivi.
SK	Čistení je nutné vykonávať výhradne pomocí utierky alebo ľahko zvlhnutým ručníkom. Nepoužívajte čistiace prostriedky obsahujúci abrazívni častice.
TR	Lütfen sadece bir toz bezilye veya hafif nemli yumuşak bir bezle siliniz. Aşındırıcı temizlik malzemeleri kullanmayınız.







	6.0x11	6.4X50	4mm	8.0x30	
Z1	F1	K1	I2	D	C2
2	4	5	1	2	2

1

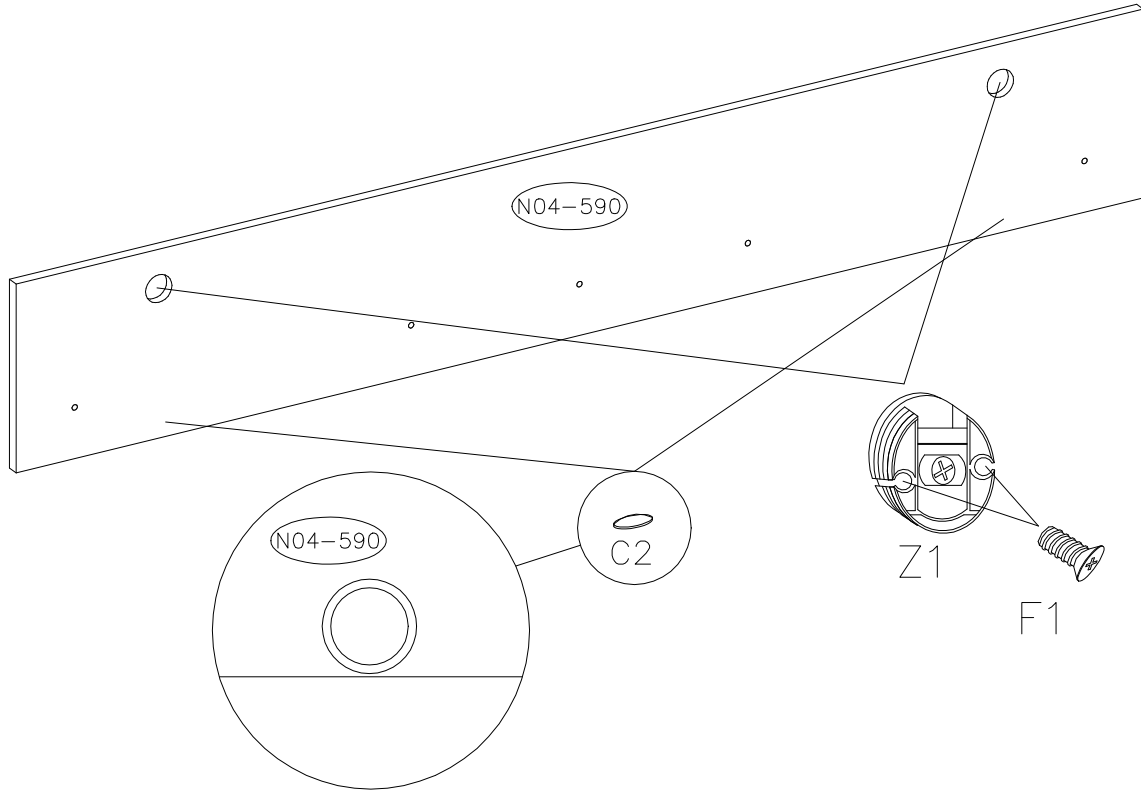
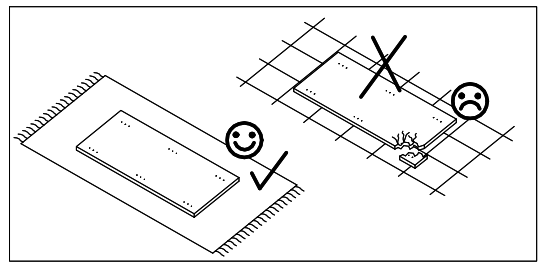

 Z1	6.0x11  F1	 C2
2	4	2

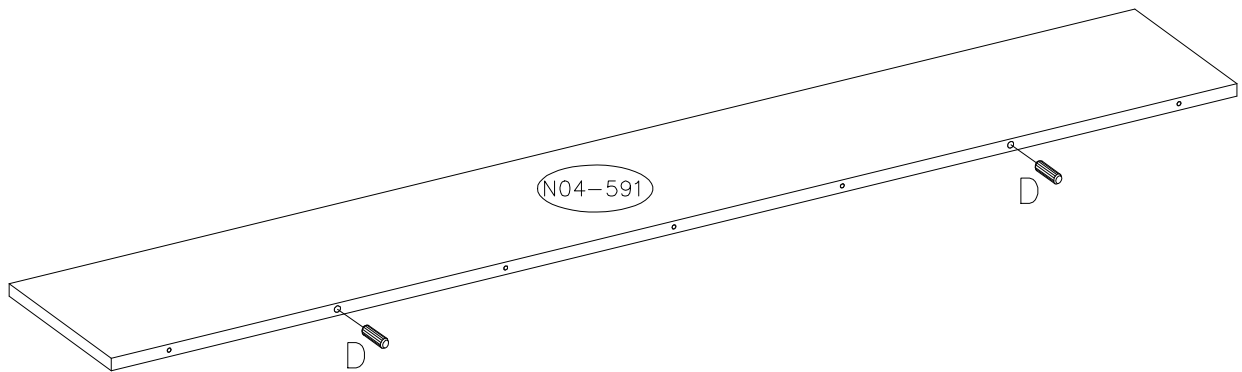

2

8.0x30  D
2

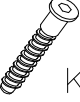

6.4X50
 K1
5
4mm
 12
1

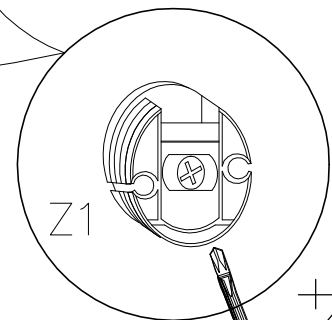
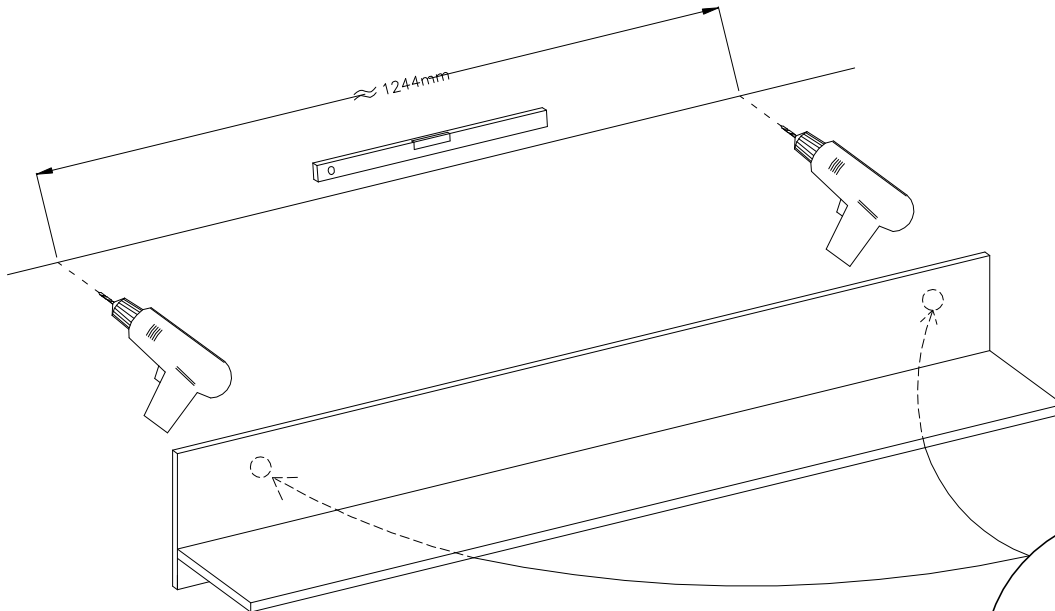
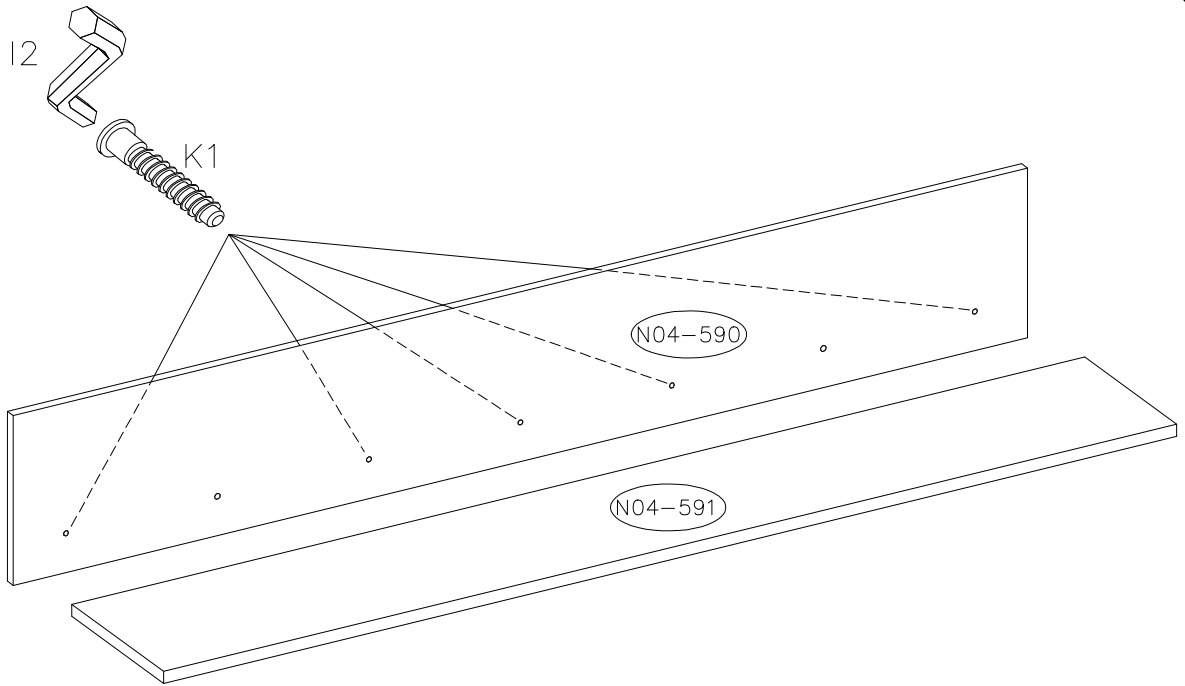

**! Uwaga • Upozornini • Achtung • Attention • Caution • Figyelem • Attensione • Opgelet • Внимание • Atentie • Upozornenie • Dikkat !**

PL	Mocowanie mebla do ściany może przeprowadzić wyłącznie odpowiedni do tego personel, ponieważ w czasie montażu w ścianie konieczne jest zastosowanie dopasowanych kołków.
CZ	Připevnění nábytku ke stěně může uskutečnit výhradně k tomu určený personál, protože pro montáž je nutné použít hmoždinky shodné s typem a tloušťkou stěny.
D	Die Befestigung des Möbelstückes an der Wand muss von einer fachkundigen Person vorgenommen werden, da für die Montage an die Wand angepasste Dübel erforderlich sind.
GB	A qualified professional is required when mounting furniture to the wall since dowels corresponding to the wall are required for this.
F	Le montage du meuble au mur peut être fait uniquement par le personnel spécialisé. Il est nécessaire d'utiliser des chevilles bien ajustées pendant le montage au mur.
HU	A bútor a falhoz való rögzítését kizárólag erre illetékes személyzet végezheti, mivel a falhoz való rögzítés során megfelelő méretű csapszeg alkalmazása szükséges.
I	Attaccare un mobile alla parete può essere effettuato esclusivamente dal personale adatto perche' durante il montaggio bisogna usare dei cavicchi adatti.
NL	een vakkundige persoon dient het meubelstuk aan de muur te bevestigen; voor de montage aan de muur zijn immers aangepaste pluggen vereist.
RU	Поскольку для монтажа на стене необходимо использовать специальные дюбели, мебель должна быть закреплена на стене квалифицированным персоналом.
RO	Montarea mobilei pe perete poate fi efectuată numai de către personalul calificat deoarece la această montare se folosește cepuri.
SK	Pripevnění nábytku k stěně může uskutečnit výhradně k tomu určený personál, pretože k montáži je nutné použiť hmoždinky zhodné s typom steny a jej hrúbkou.
TR	Möbilya parçasının duvara sabitlemesi, duvar montajı için özel uyarlanmış dübeller gerektirdiğinden bu iş sadece bu konuda uzman bir kişi tarafından gerçekleştirilmelidir.

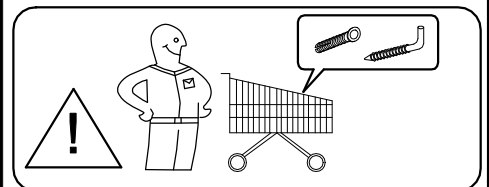
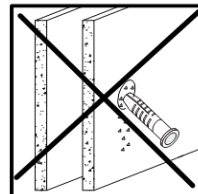
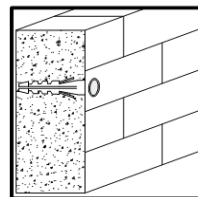

(PL) Instrukcja montażu

(CZ) Návod k montáži

(D) Montageanleitung

(GB) Assembly instruction

(F) Model d'emploi

(HU) Szerelési útmutató

(I) Istruzione di montaggio

(NL) Handleiding voor de montage

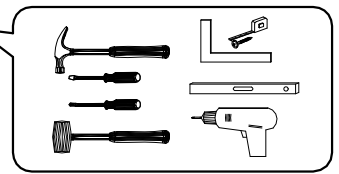

(RU) Инструкция по монтажу

(RO) Instrucțiuni de montare

(SK) Návod k montáži

(TR) Montaj talimatı

⚠ <b>Uwaga • Upozornění • Achtung • Attention • Caution • Figyelem</b> <b>Attenzione • Opgelet • Внимание • Atenție • Upozornenie • Dikkat</b> ⚠	
PL	Czyszczenie należy wykonać wyłącznie za pomocą ściereczki lub lekko nawilżonego ręcznika. Nie stosować środków czyszczących do szorowania.
CZ	Čistění je nutné vykonávat výhradně pomocí utěrky nebo lehce navlhčeného ručníku. Nepoužívejte čisticí prostředky obsahující abrazivní částice.
D	Bitte nur mit einem Staubtuch oder leicht feuchtem Lappen reinigen. Keine scheuernden Putzmittel verwenden.
GB	Please only clean with a duster or a damp cloth. Do not use any abrasive cleaners.
F	Le nettoyage se fait uniquement à l'aide d'un torchon ou d'une serviette légèrement mouillée.
HU	A tisztítás kizárólag törülköruha vagy enyhén nedvestett törölköző segítségével végezhető. Súroló hatású tisztítószereket nem szabad használni.
I	Pulire esclusivamente con un panno o un asciugamano umido.
NL	Reinig alleen met een stofdoek of een lichtjes vochtige doek. Gebruik geen schurende poetsmiddelen.
RU	Очищайте от пыли тряпкой или слегка влажной ветошью. Не допускается применение чистящих средств, не предназначенных для ухода за мебелью.
RO	Curățarea trebuie efectuată numai cu o cârpă sau cu un prosop ușor umezit. Nu utilizați agenți de curățare abrazivi.
SK	Čistení je nutné vykonávať výhradne pomocou utierky alebo ľahko zvlhnutým ručníkom. Nepoužívajte čistiace prostriedky obsahujúci abrazívni častice.
TR	Lütfen sadece bir toz bezilye veya hafif nemli yumuşak bir bezle siliniz. Aşındırıcı temizlik malzemeleri kullanmayınız.

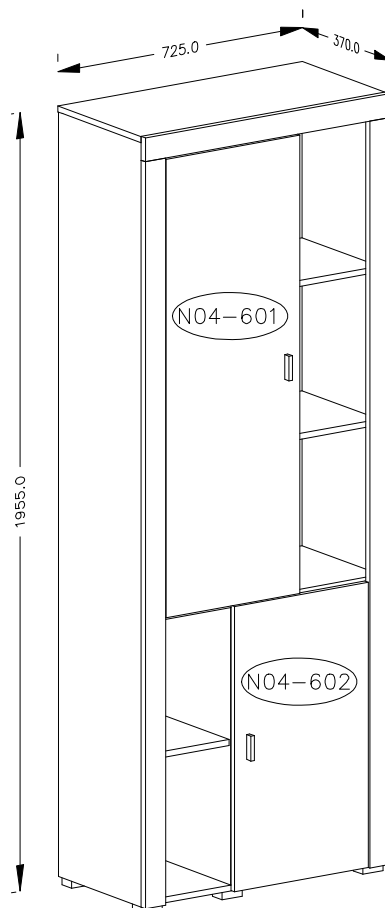
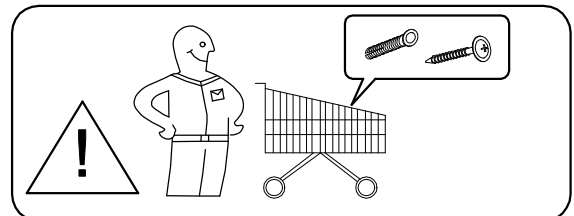
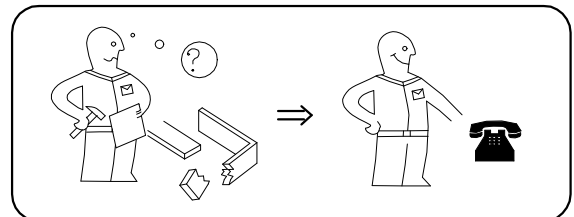
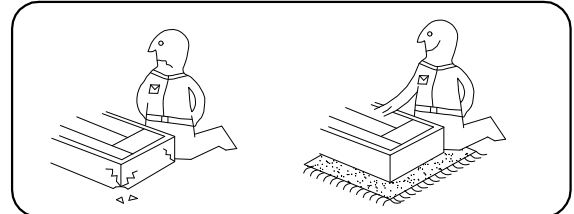

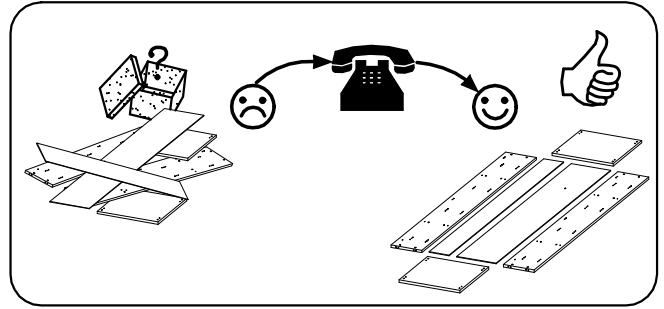
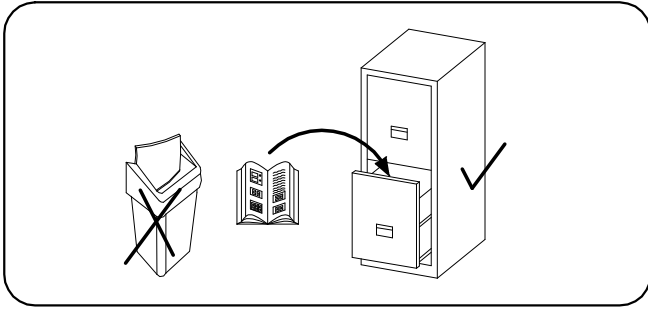

MAX  
5kg

(N04-450) (N04-501) (N04-502)

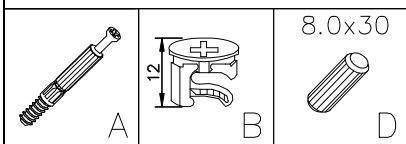
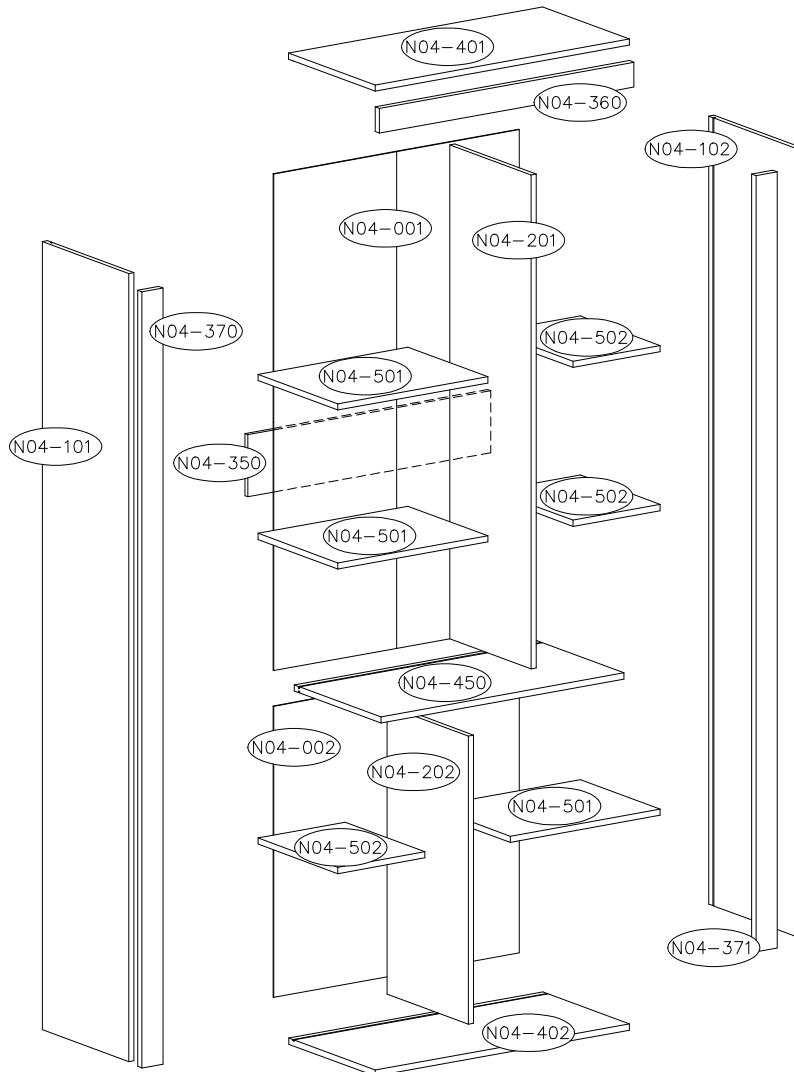

35 39 30

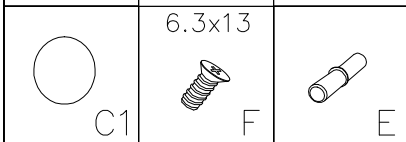

34 10 24

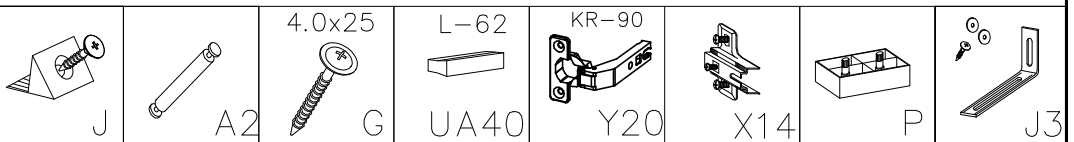

16 2 4 2 5 5 6 2

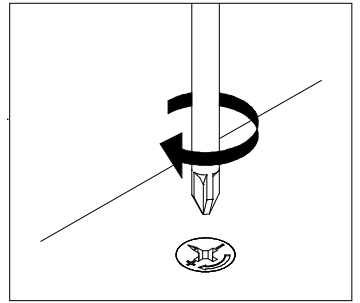
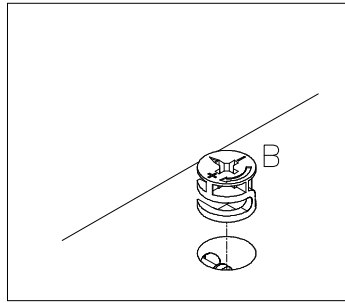
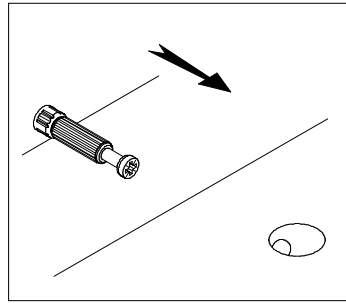
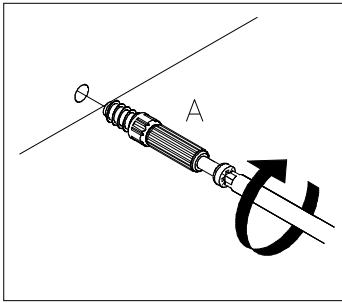

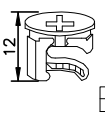
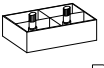

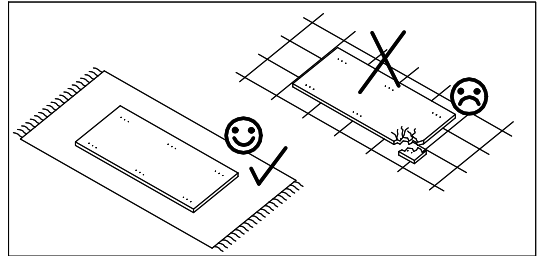
		8.0x30	
A	B	D	P
12	11	10	6



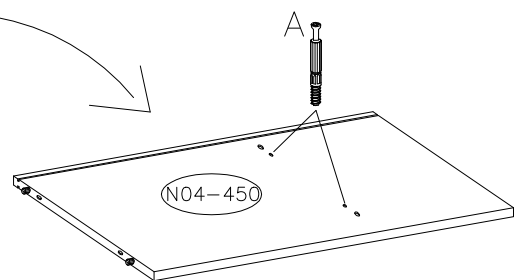
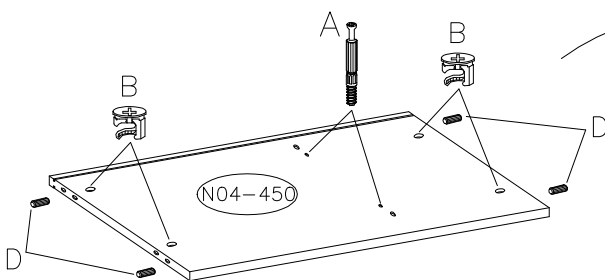
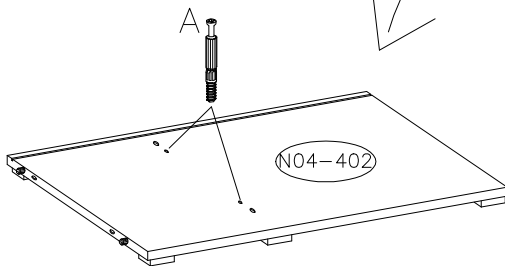
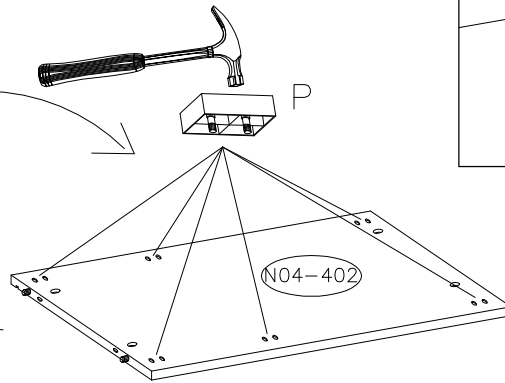
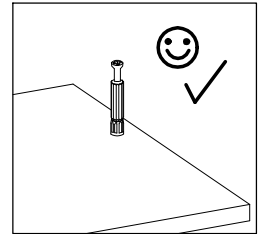
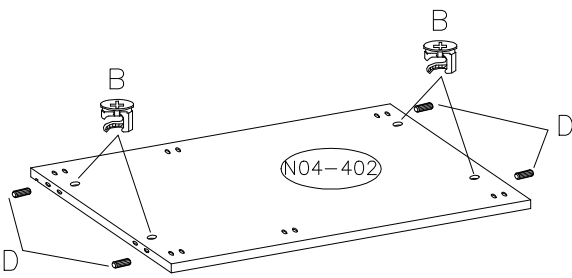
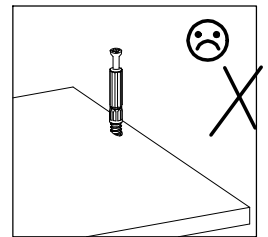
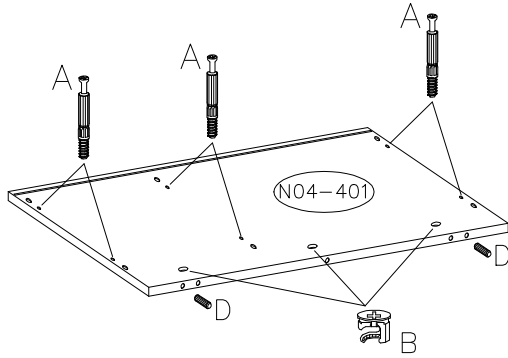

1

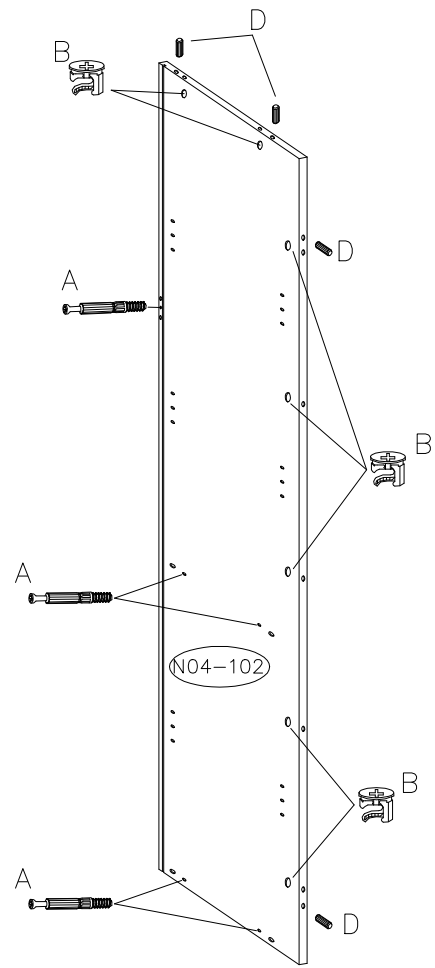
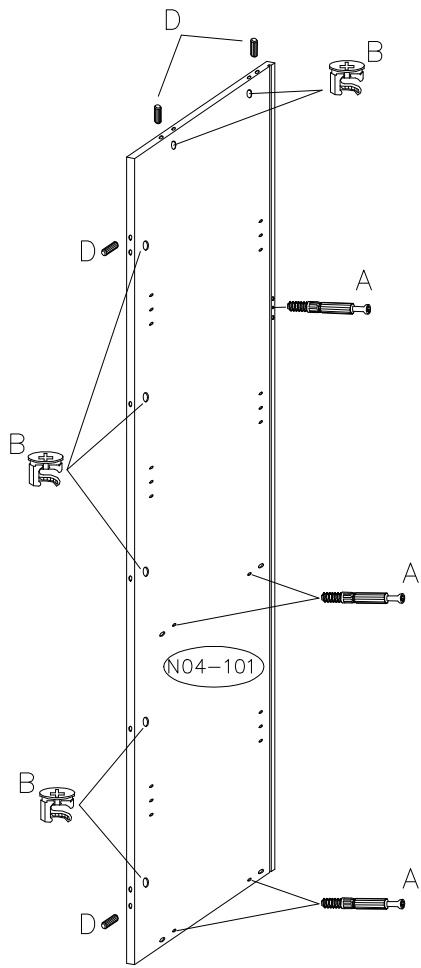

	A
10	
	B
14	
8.0x30	
	D
8	



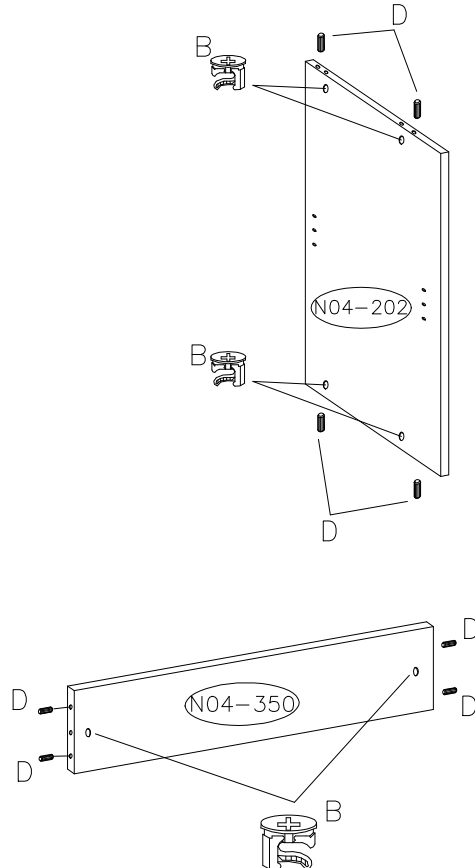
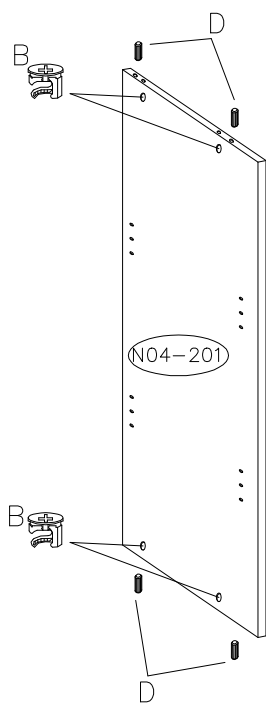

	B
10	
8.0x30	
	D
12	



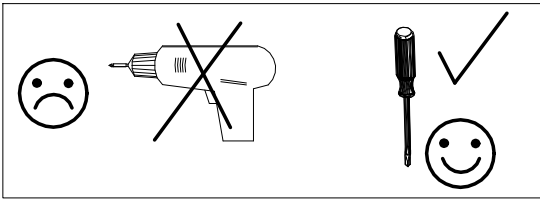

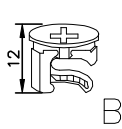

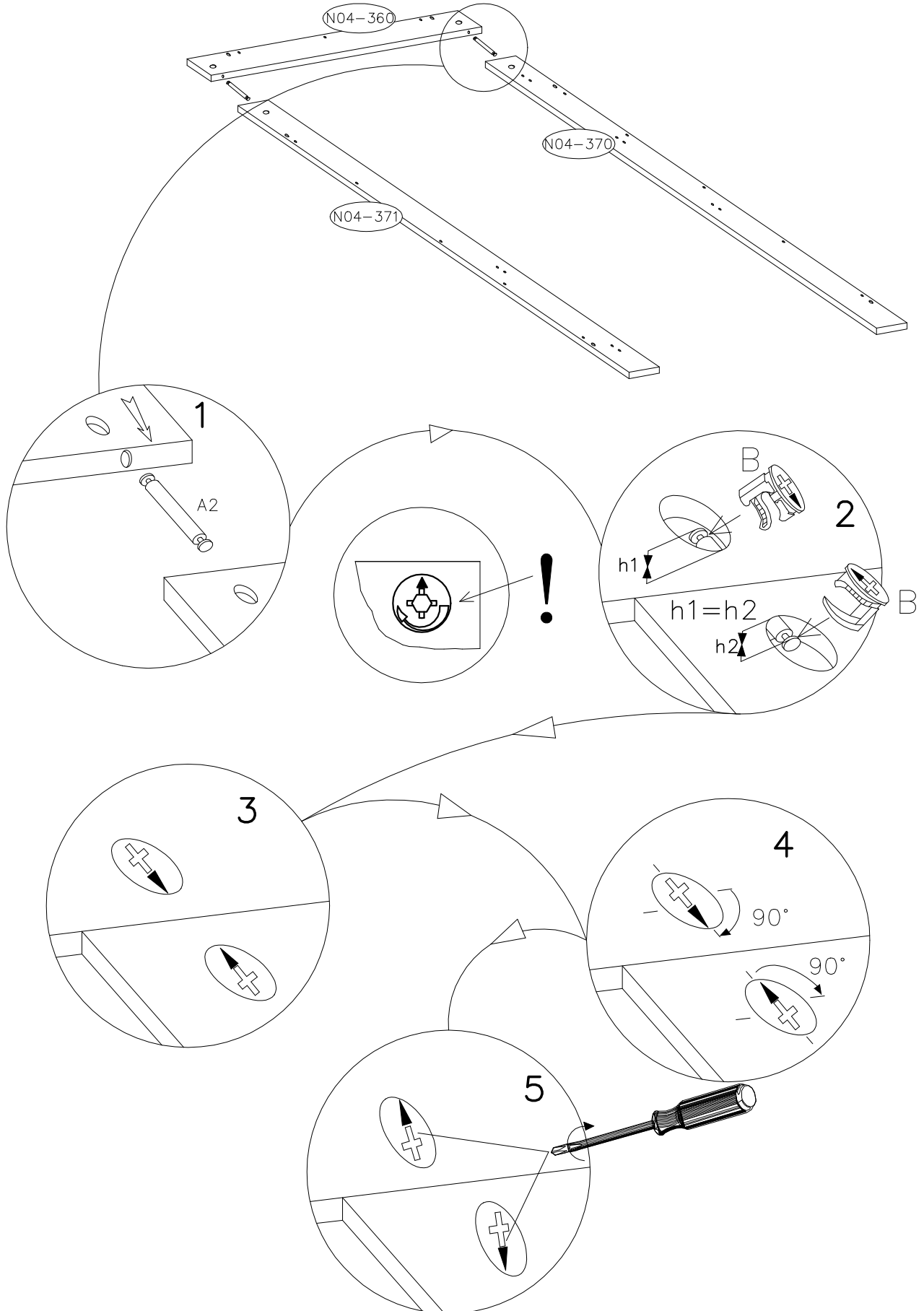

 12 B	 A2
4	2



	
X14	A
5	13

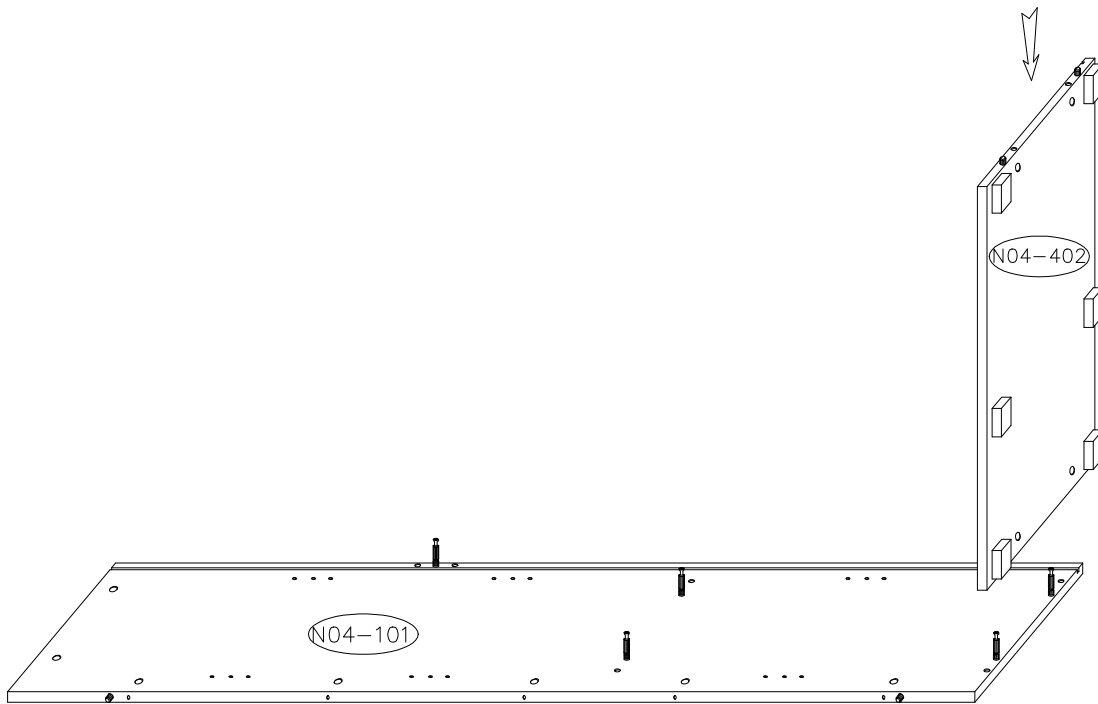
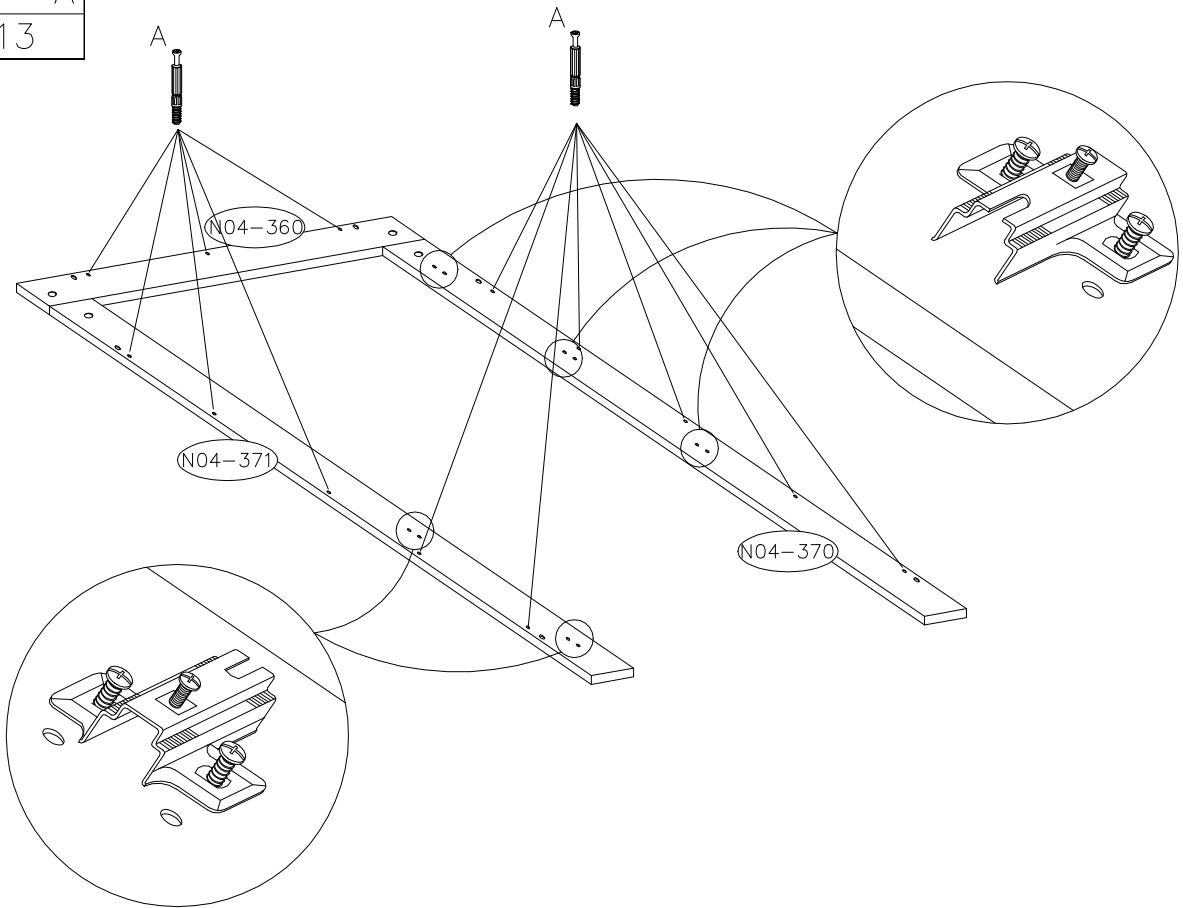

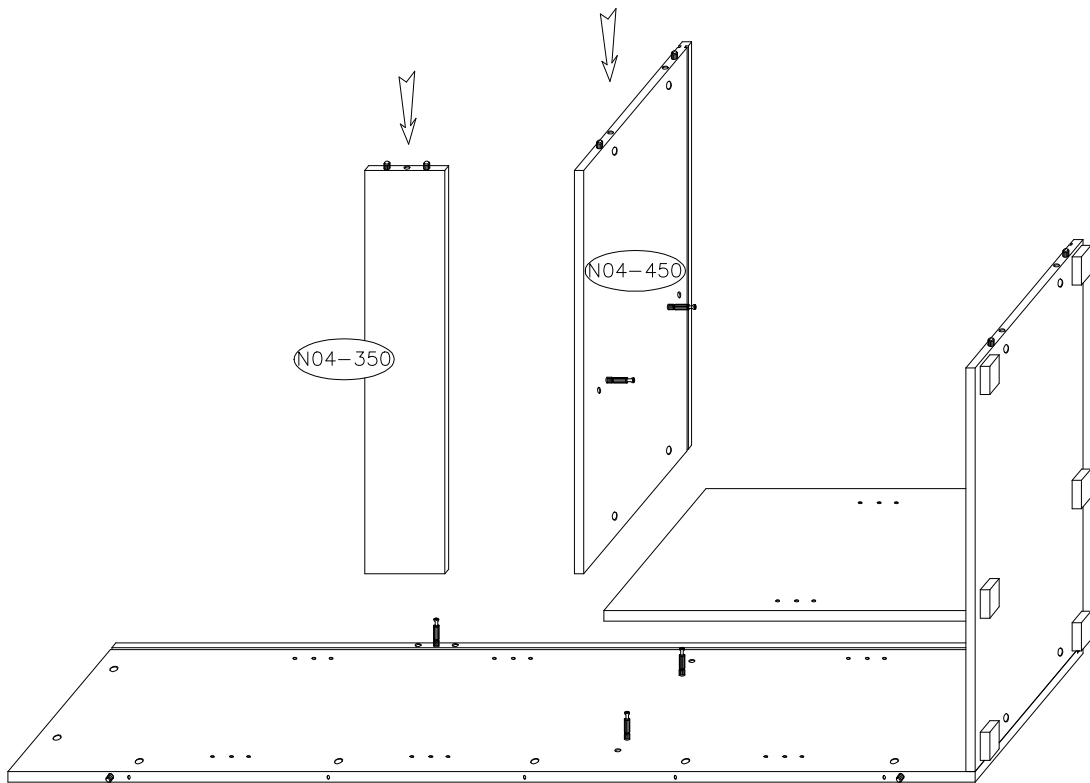
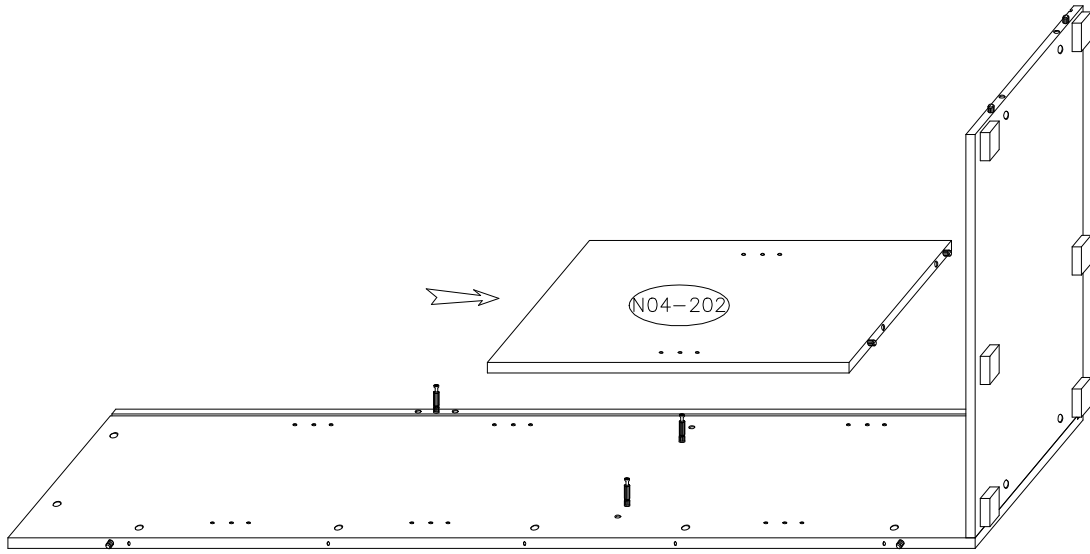

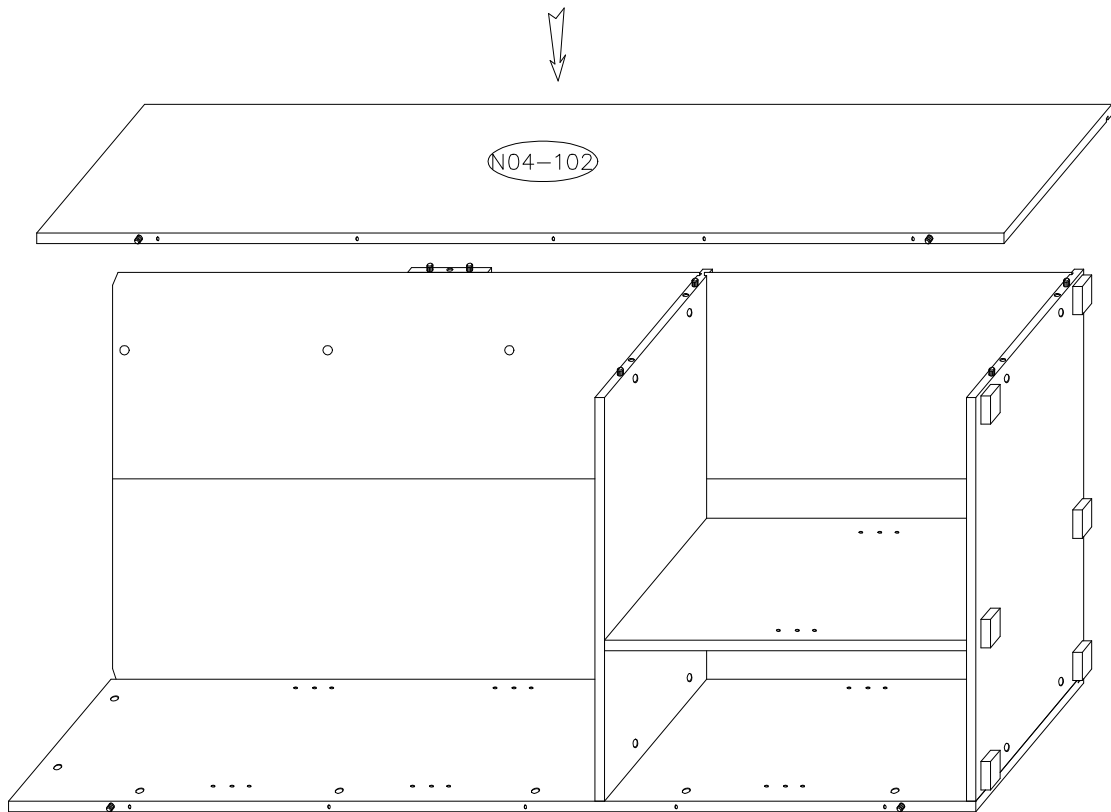
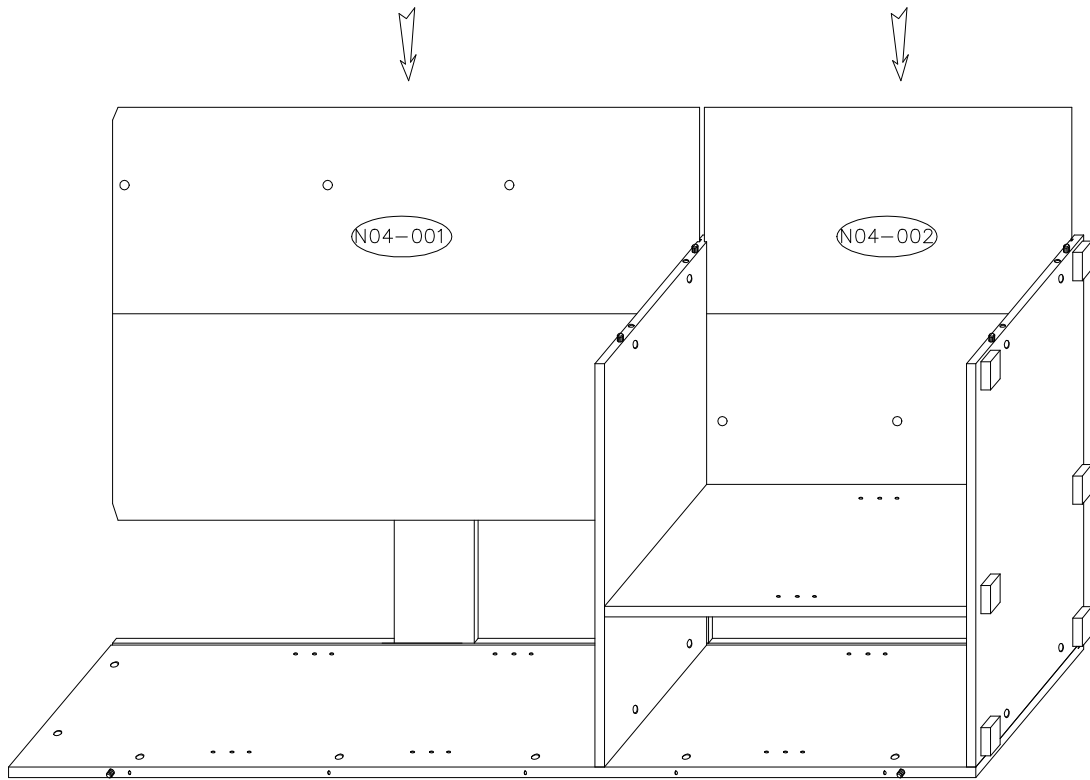

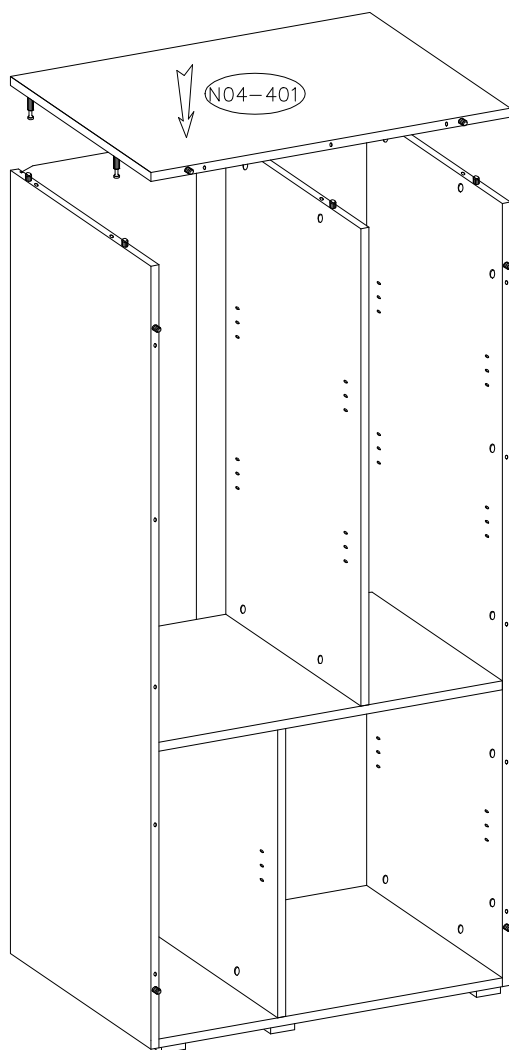
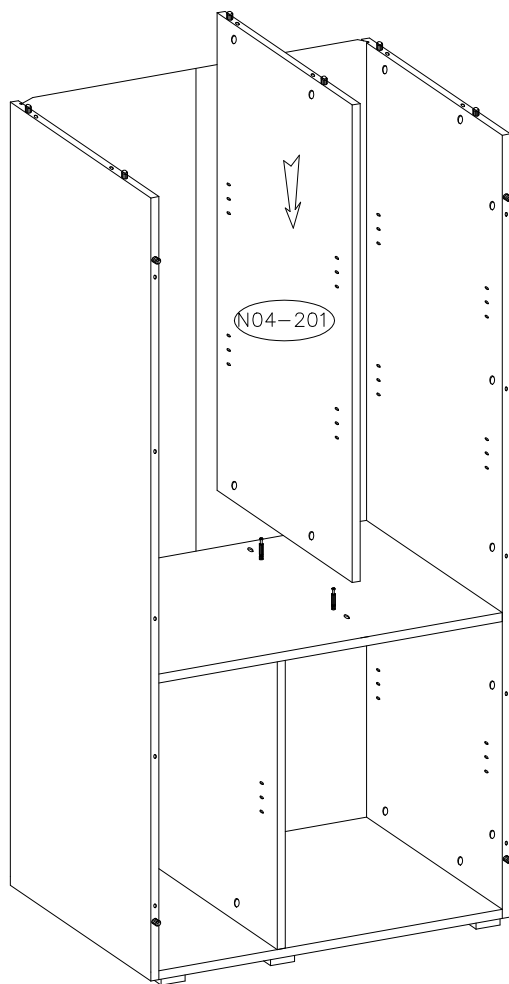

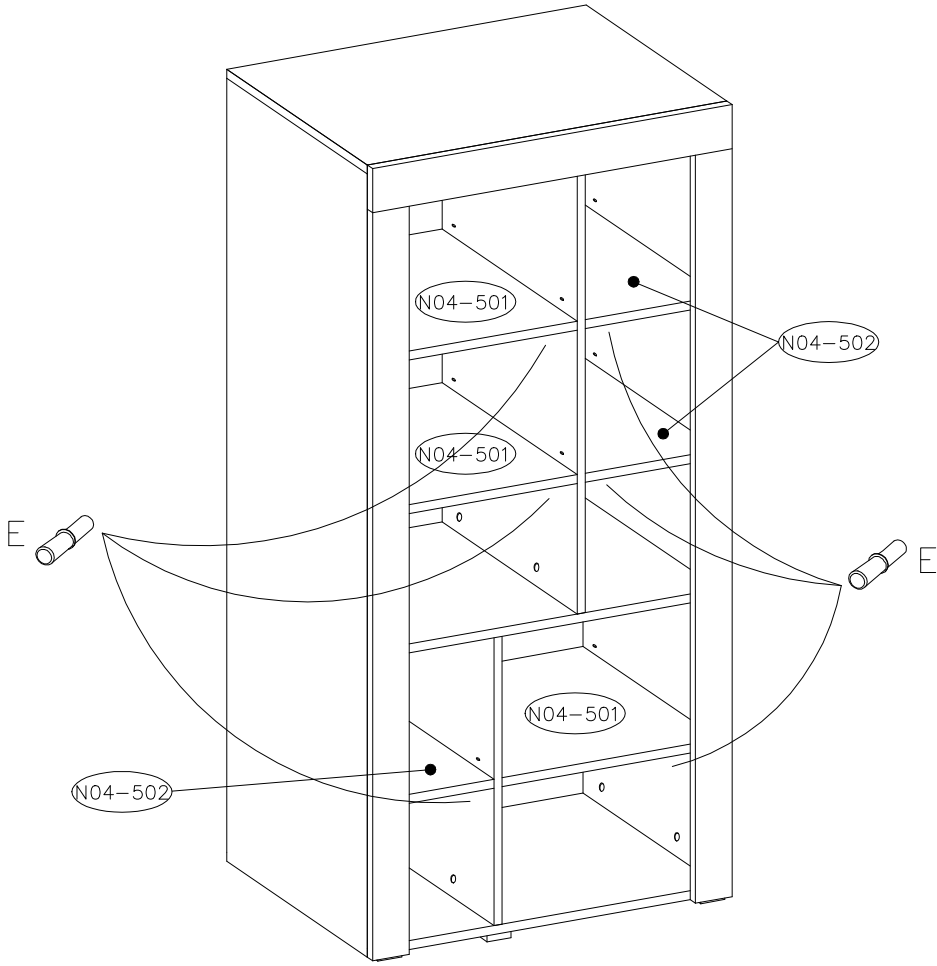
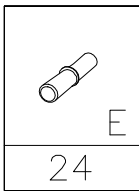
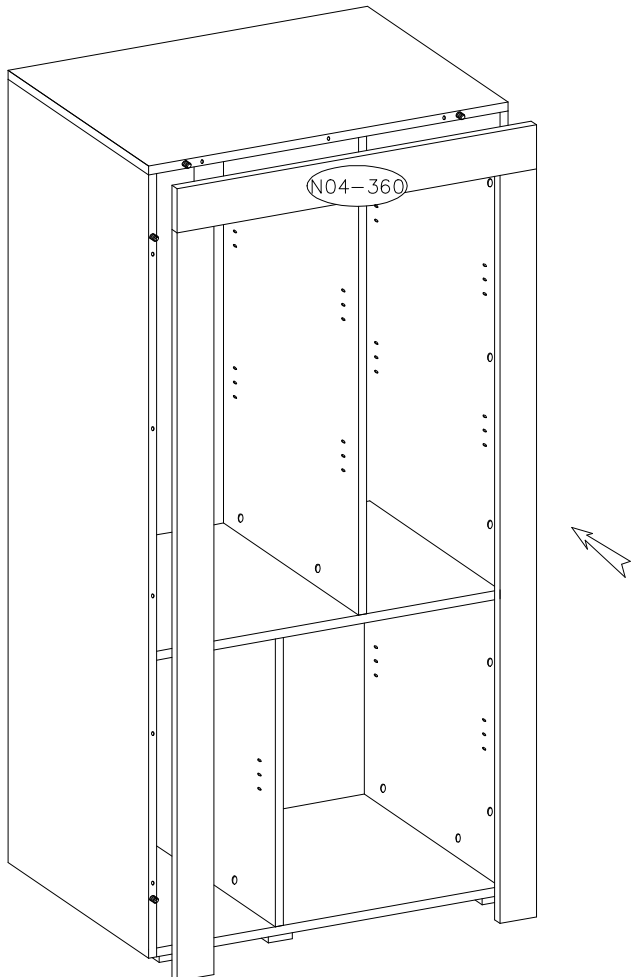





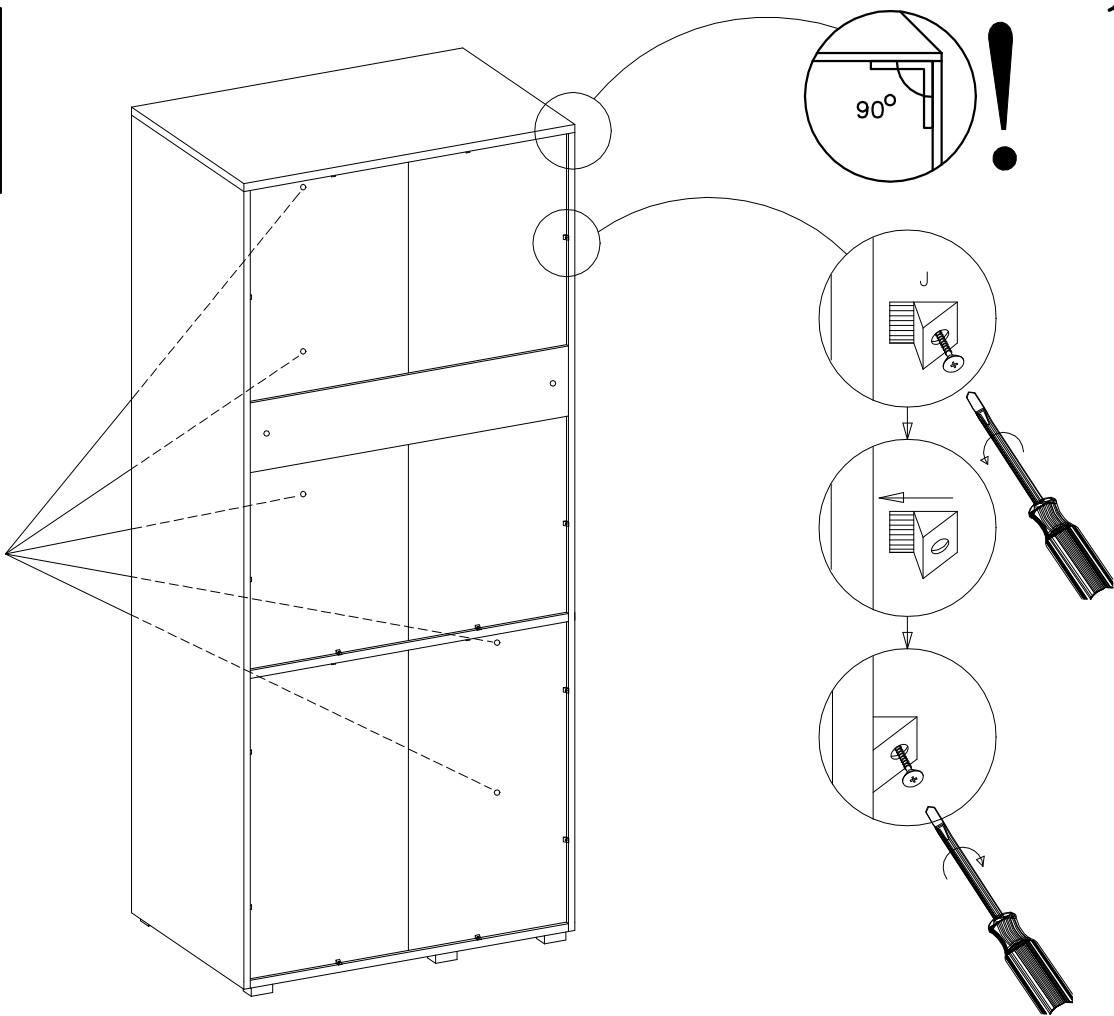

 J	 C1
16	5

C1

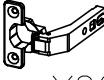

6.3x13  F	4.0x25  G	L-62  UA40	KR-90  Y20
10	4	2	5

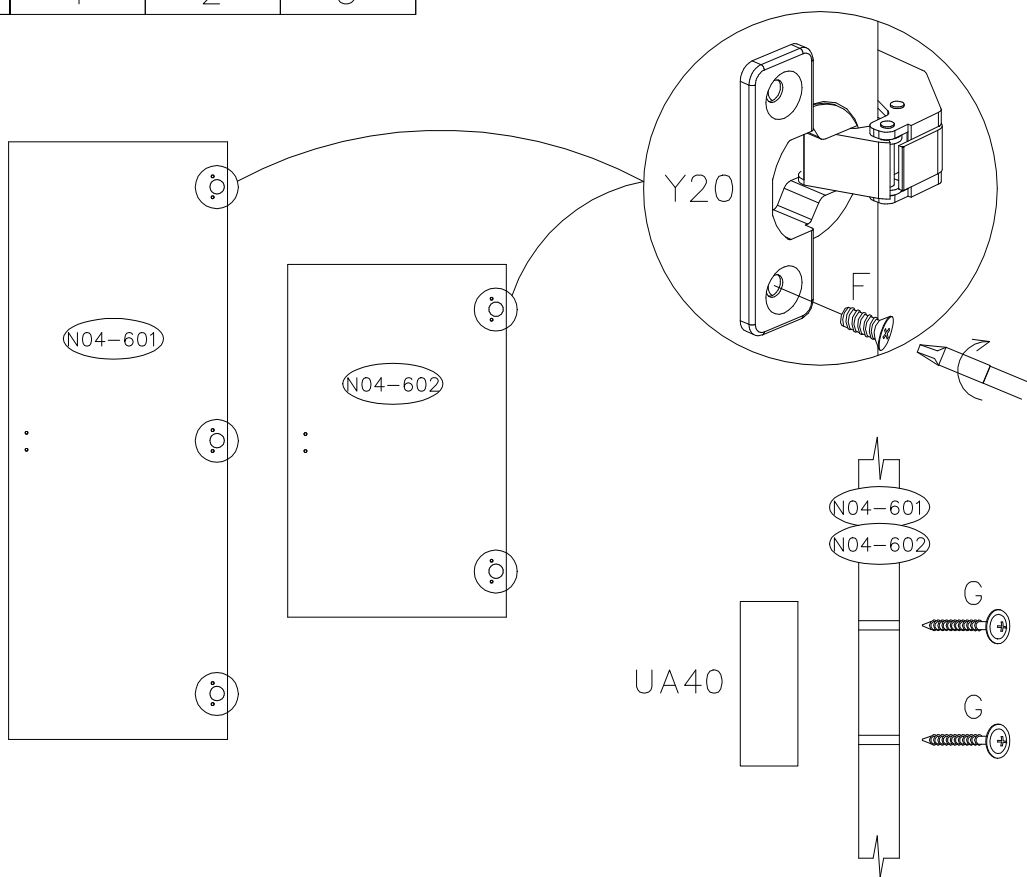

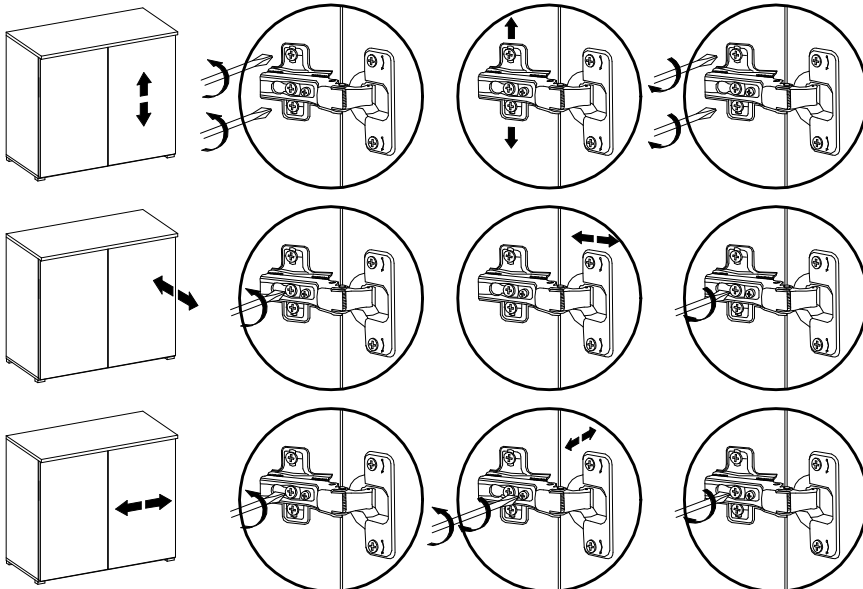
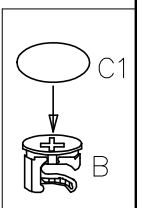
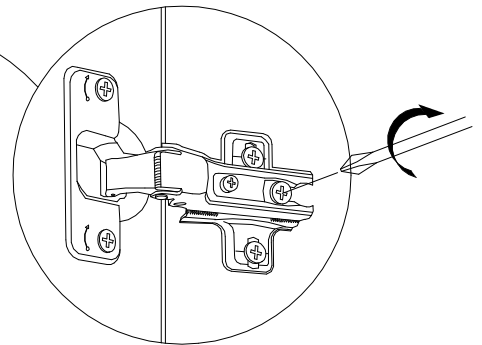
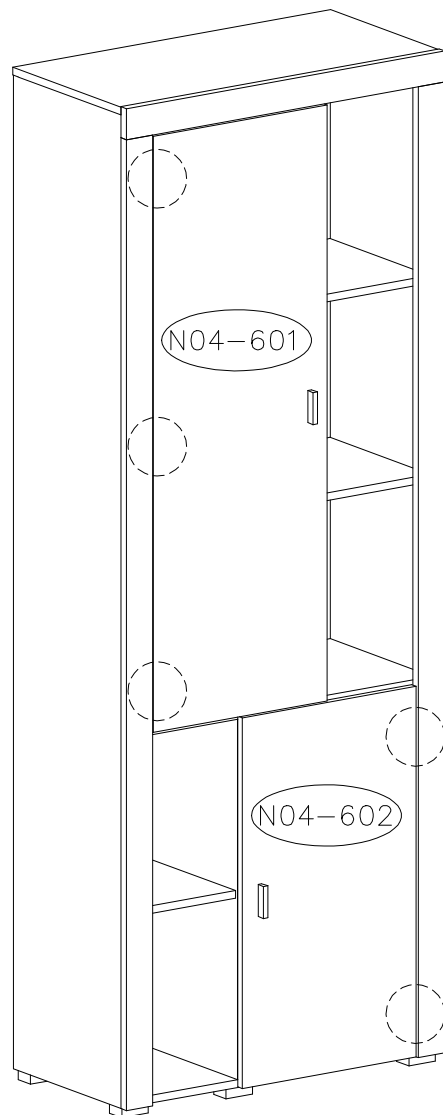
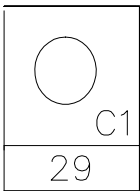

- F** Mettre la porte (égaliser les gonds)
- I** Regolare la porta (livellare le parentesi)
- D** Turen einstellen (Scharniere justieren)
- GB** Adjusting the doors (adjusting the hinges)
- NL** Deuren instellen (scharnieren afstellen)
- PL** Nastawic drzwi (wyrównac zawiasy)
- TR** Kapıların ayarlanması (menteşelerin seviye ayarı)
- RU** Регулировка дверей (регулировка шарнира)
- RO** Ajustați ușa (aliniati balamalele)
- CZ** Seřid'te dveře (vyrovnajte závěsy)
- SK** Zrad'te dvere (vyrovnajzte závěsy)
- HU** Állítsa be az ajtót (igazítsa be a zsanérokot)



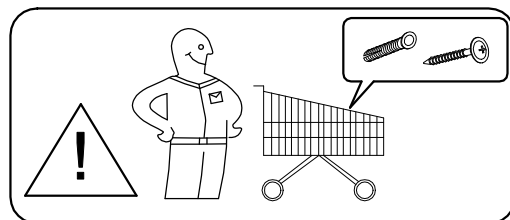
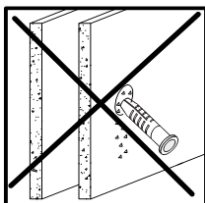
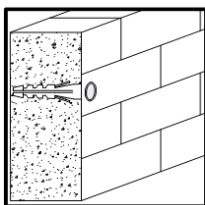
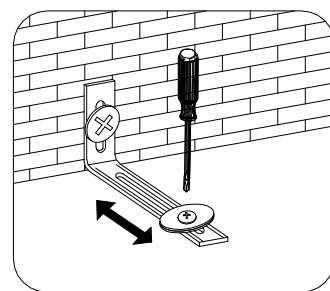
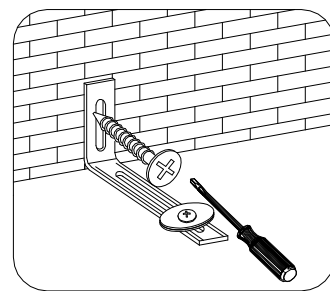
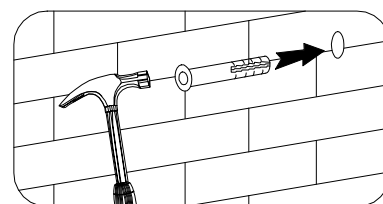
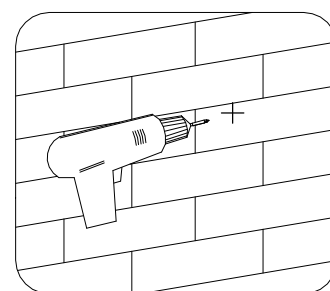
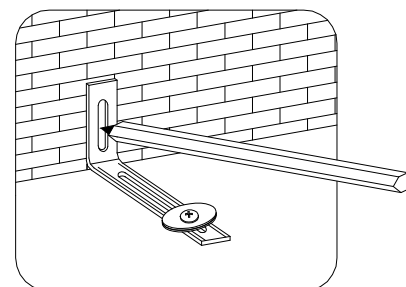
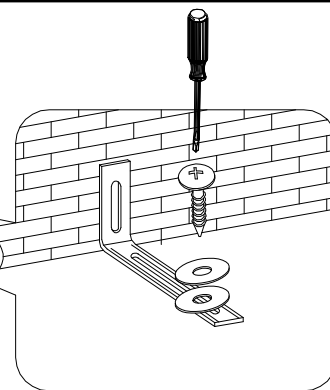
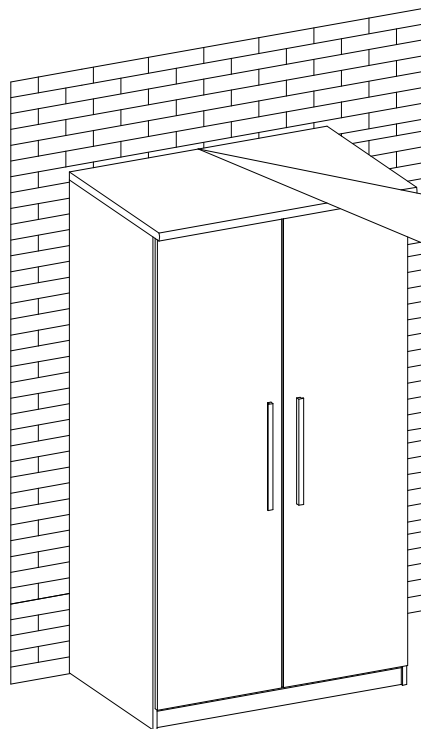
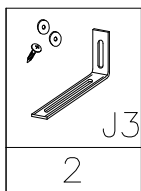

**! Uwaga • Upozornini • Achtung • Attention • Caution • Figyelem !  
 Attenzione • Opgelet • Внимание • Atentie • Upozornenie • Dikkat !**

PL	Mocowanie do ściany jest jednocześnie zabezpieczeniem przed przewróceniem – konieczne zamontować!
CZ	Do některých druhů stěn je nutné použít speciální vrtací šrouby – šrouby se kupují samostatně. U některých typů stěn může být zapotřebí speciální hmoždinka – hmoždinka zákazník kupuje!
D	Wandbefestigung dient als Kippschutz – unbedingt anbringen! Bei einigen Wandtypen kann ein Spezialdübel erforderlich sein – Spezialdübel Kunde kauft!
GB	The wall fastening serves to prevent tipping – be absolutely sure to mount it! For certain wall types, a special wall plug may be necessary – special wall plug buy customer!
FR	La fixation murale sert de protection contre le basculement – à installer impérativement ! Pour certains types de murs il faut des chevilles spéciales – chevilles client achète!
NL	Bevestiging aan de muur dient als kantelbescherming – zeker en vast bevestigen! Bij enkele muurtypes is een speciale plug misschien vereist – plug klant koopt!
IT	Il fissaggio alla parete serve da protezione anti-ribaltamento – attaccarla assolutamente! Per alcune strutture di parete può essere necessario un tassello speciale – Cliente acquista tassello!
HU	A termék a falhoz kel rögzítési, különben az felborulhat! Egyes faltípusoknál speciális tiplít kell használni – gombostű ügyfél vásárol!
RU	Обязательно установите крепление на стене во избежание опрокидывания! Для некоторых типов стен может потребоваться специальный дюбель – Дюбель покупаем клиентом!
RO	Sistemul de fixare la perete serve ca protecție la răsturnare – de montat obligatoriu! Pentru unele tipuri de pereți este posibil să fie necesar un diblu special – un diblu cumpărat de clienții!
SK	Upevnenie na stenu slúži ako ochrana proti prevráteniu – bezpodmienečne použite! Pre niektoré druhy stien môže byť potrebná špeciálna hmoždinka – hmoždinka Zákazník kupuje!
TR	Duvardaki sabitleme, devrilmeye karşı bir emniyet tedbiridir ve mutlaka monte edilmelidir! Bazı duvar tiplerinde bunun için özel bir dübel gerekli olabilir – Pins müşteri satın alıyor!

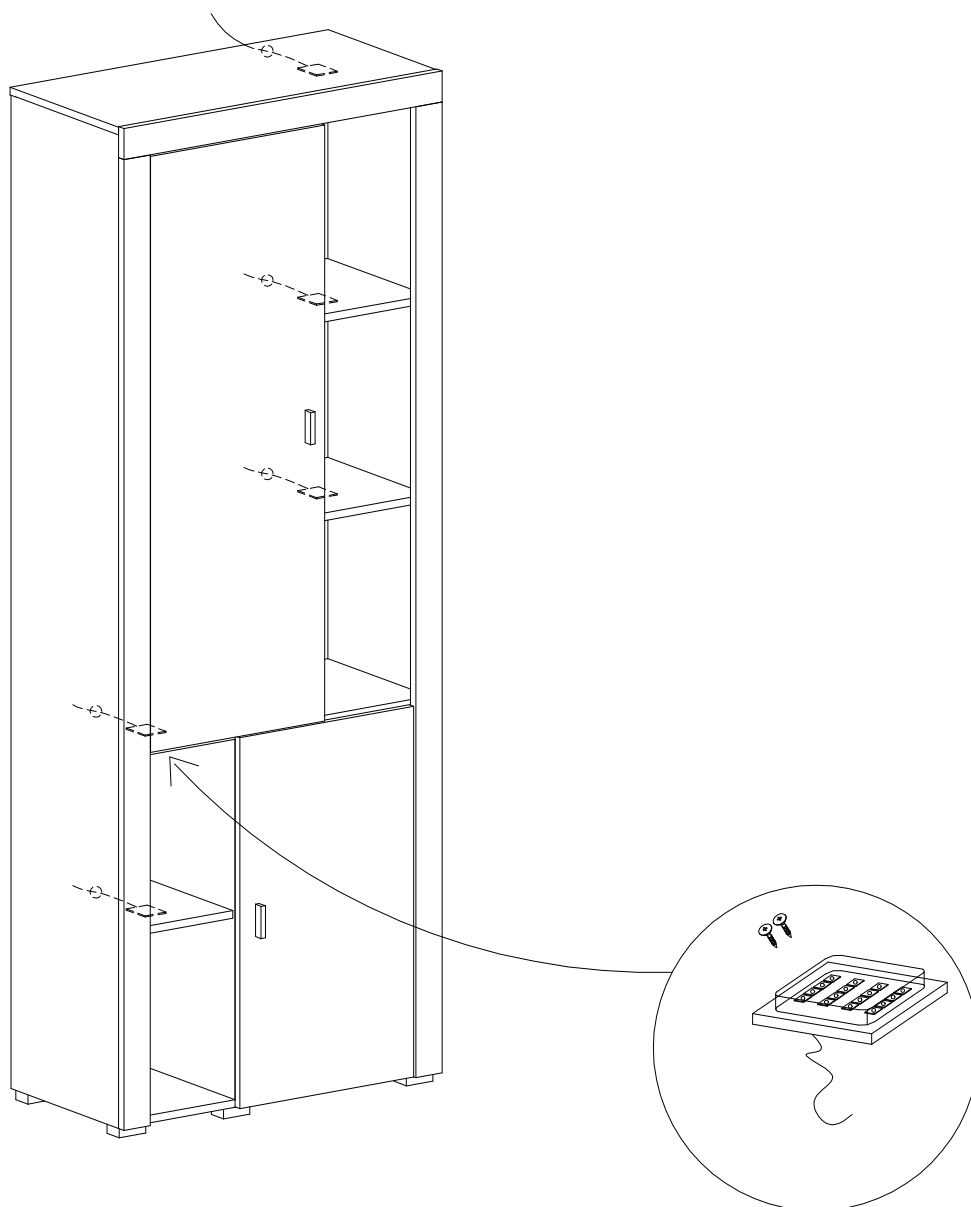
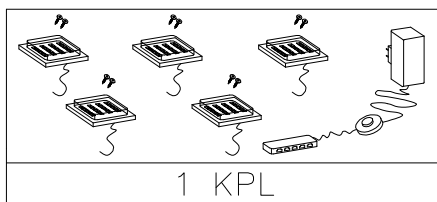

- (PL) **Uwaga: Punkty mocowania opcjonalnego oświetlenia**
- (CZ) **Upozornění: body k připevnění doplňkového osvětlení**
- (D) **Hinweis: Befestigungspunkte für optionale Beleuchtung**
- (GB) **N.B.: Fixing points for optional lighting**
- (F) **Remarque: Points de fixation de l'éclairage optionnel**
- (HU) **Figyelem: Opcionális világítás rögzítési pontjai**
- (I) **NOTA: punti di fissaggio opzionale dell'illuminazione**
- (NL) **OPGELET: Optionele bevestigingspunten van de verlichting.**
- (RU) **ВНИМАНИЕ: Точки крепления дополнительного освещения**
- (RO) **Atenție: Punctele opționale de fixare a iluminatului**
- (SK) **Upozornenie: body k pripevnení dodatočného osvetlení**
- (TR) **Dikkat: Seçenekli aydınlatmanın yerleştirilmesinin noktaları**

(PL) Instrukcja montażu

(CZ) Návod k montáži

(D) Montageanleitung

(GB) Assembly instruction

(F) Model d'emploi

(HU) Szerelési útmutató

(I) Istruzione di montaggio

(NL) Handleiding voor de montage

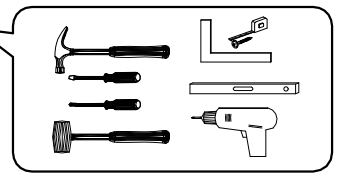

(RU) Инструкция по монтажу

(RO) Instrucțiuni de montare

(SK) Návod k montáži

(TR) Montaj talimatı



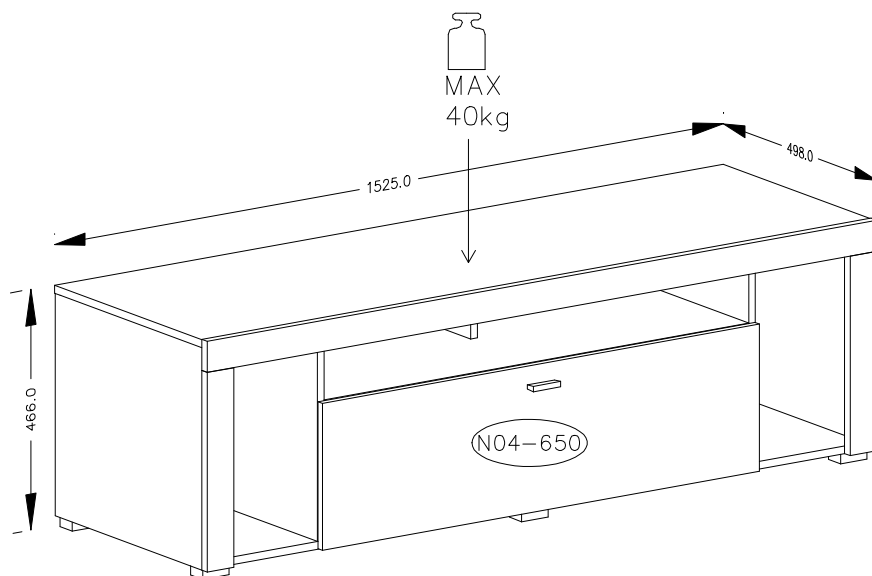
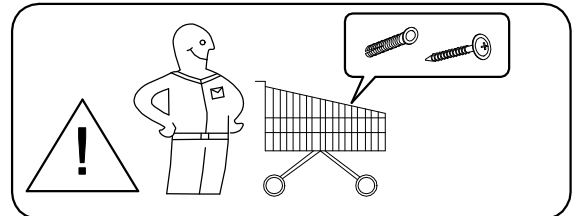
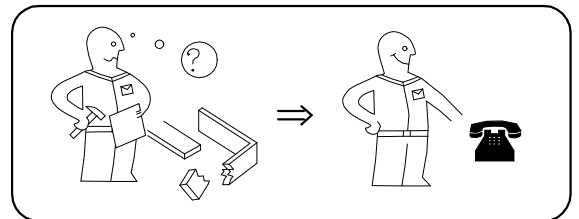
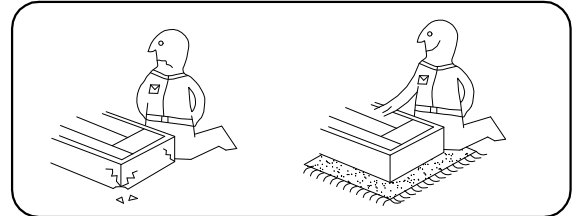

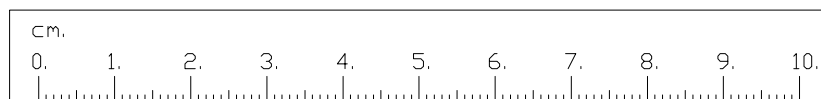
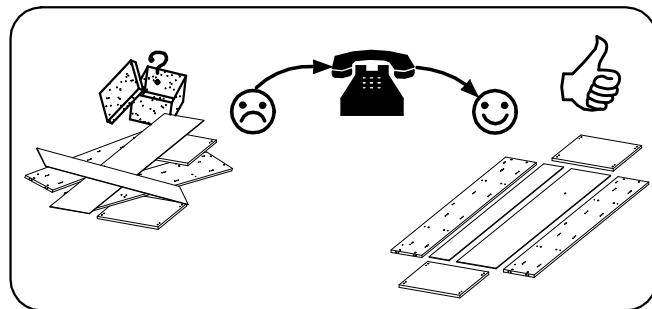
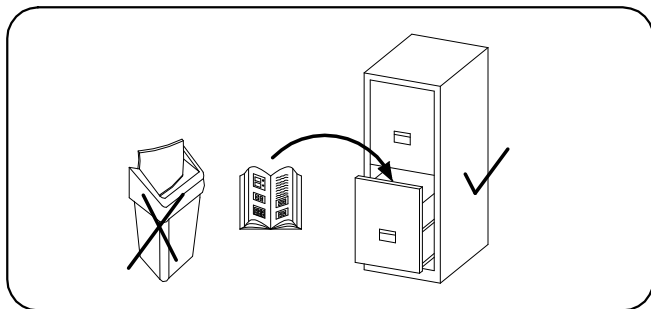

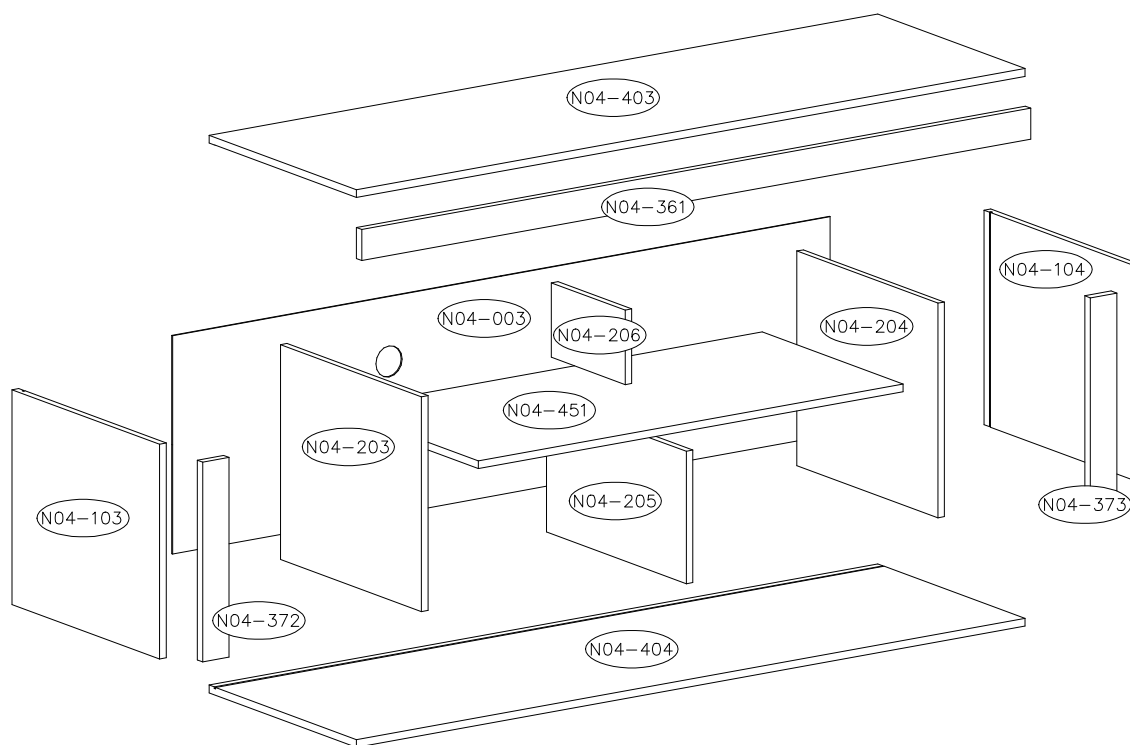

⚠ <b>Uwaga • Upozornění • Achtung • Attention • Caution • Figyelem</b> <b>Attenzione • Opgelet • Внимание • Atenție • Upozornenie • Dikkat</b> ⚠	
PL	Czyszczenie należy wykonać wyłącznie za pomocą ściereczki lub lekko nawilżonego ręcznika. Nie stosować środków czyszczących do szorowania.
CZ	Čistění je nutné vykonávat výhradně pomocí utěrky nebo lehce navlženého ručníku. Nepoužívejte čisticí prostředky obsahující abrazivní částice.
D	Bitte nur mit einem Staubtuch oder leicht feuchtem Lappen reinigen. Keine scheuernden Putzmittel verwenden.
GB	Please only clean with a duster or a damp cloth. Do not use any abrasive cleaners.
F	Le nettoyage se fait uniquement à l'aide d'un torchon ou d'une serviette légèrement mouillée.
HU	A tisztítás kizárólag törlőruha vagy enyhén nedvesített törölköző segítségével végezhető. Súroló hatású tisztítószereket nem szabad használni.
I	Pulire esclusivamente con un panno o un asciugamano umido.
NL	Reinig alleen met een stofdoek of een lichtjes vochtige doek. Gebruik geen schurende poetsmiddelen.
RU	Очищайте от пыли тряпкой или слегка влажной ветошью. Не допускается применение чистящих средств, не предназначенных для ухода за мебелью.
RO	Curățarea trebuie efectuată numai cu o cârpă sau cu un prosop ușor umezit. Nu utilizați agenți de curățare abrazivi.
SK	Čistení je nutné vykonávať výhradne pomocí utierky alebo ľahko zvlhnutým ručníkom. Nepoužívajte čistiaci prostriedky obsahujúci abrazívni častice.
TR	Lütfen sadece bir toz bezilye veya hafif nemli yumuşak bir bezle siliniz. Aşındırıcı temizlik malzemeleri kullanmayınız.

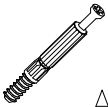
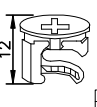
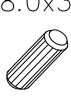
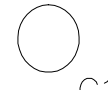

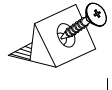



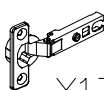

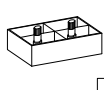
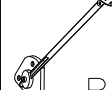
 (N04-451)  
 MAX  
 5kg

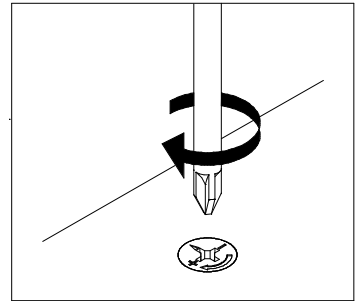
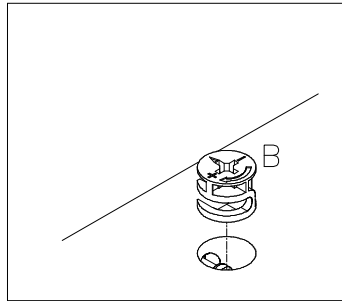
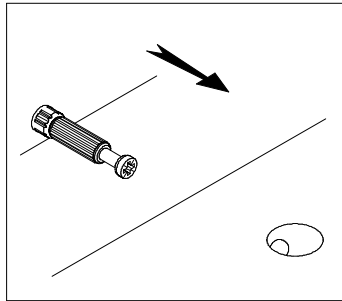
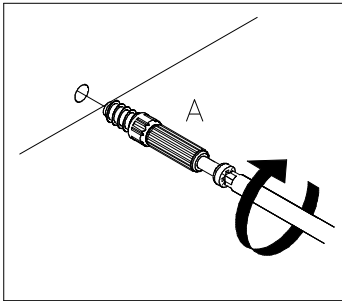

 A	 B	 D								
33	37	34								
 C1	 F	 W3	 J	 A2	 G	 UA40	 KR-0	 X14	 P	 R1
29	6	12	12	2	2	1	3	3	8	2

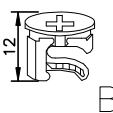
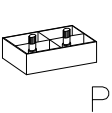

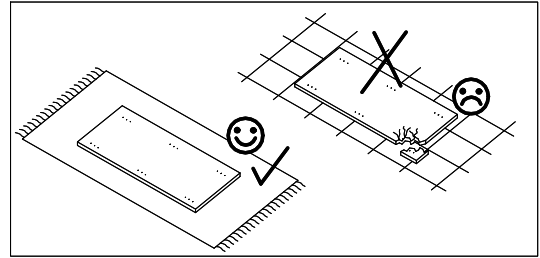

				8.0x30
A	B	P	X14	D
14	9	8	3	6



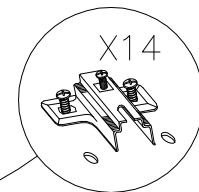
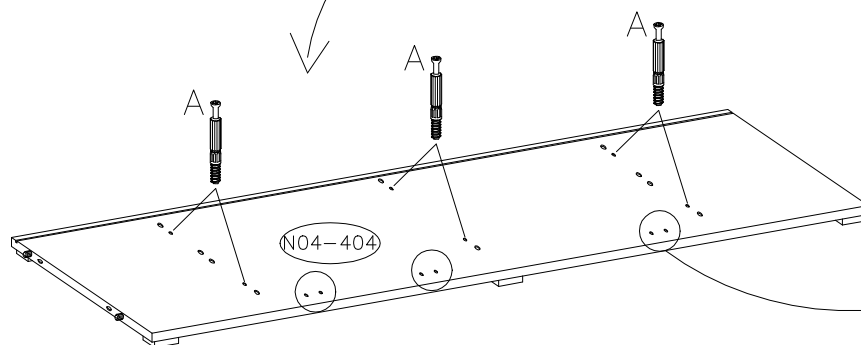
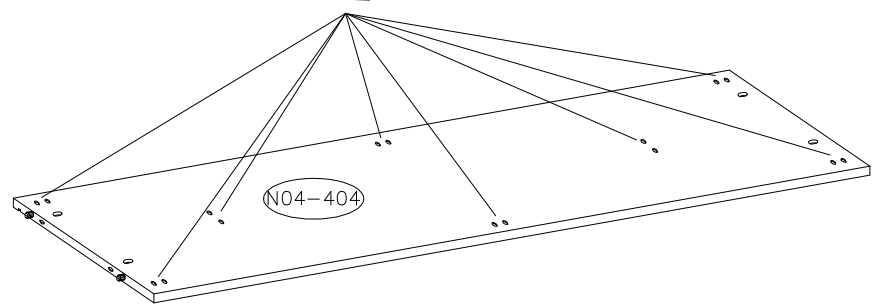
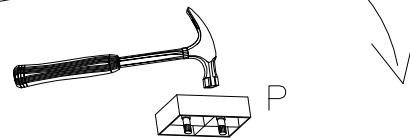
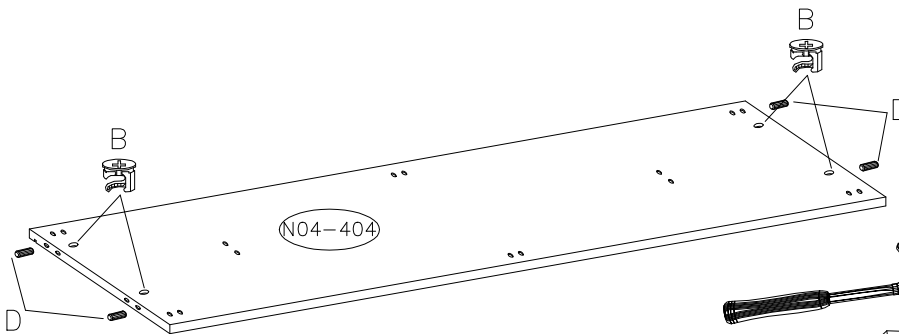
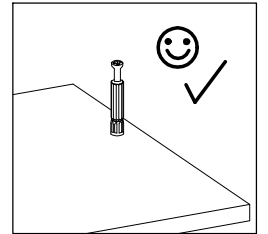
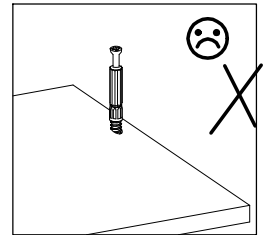
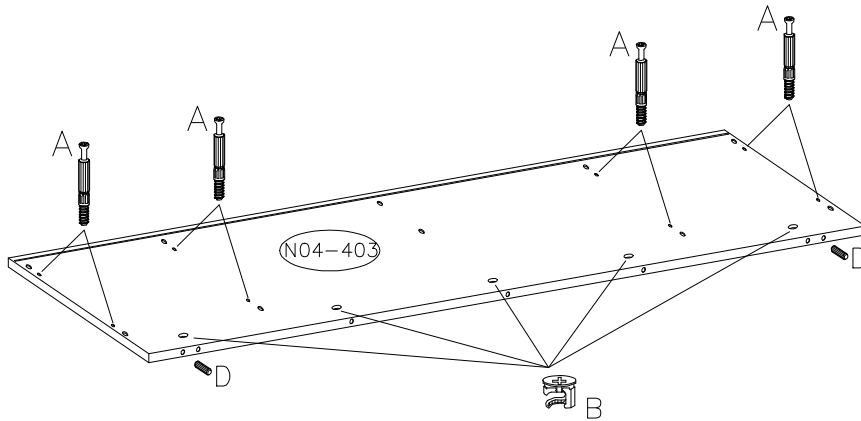

1

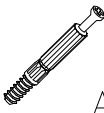

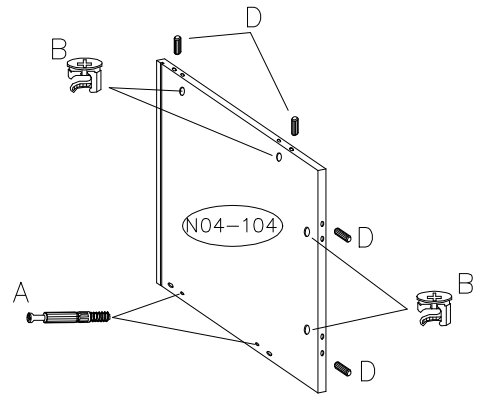
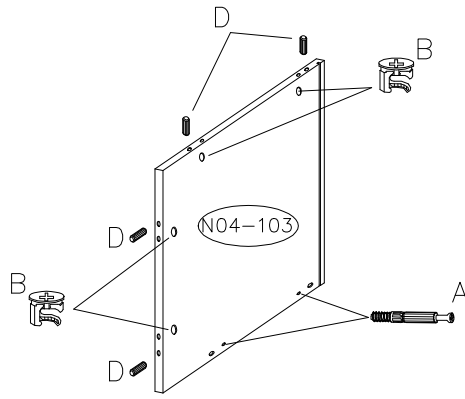

 B
8
8.0x30
 D
8
 A
4

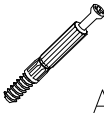

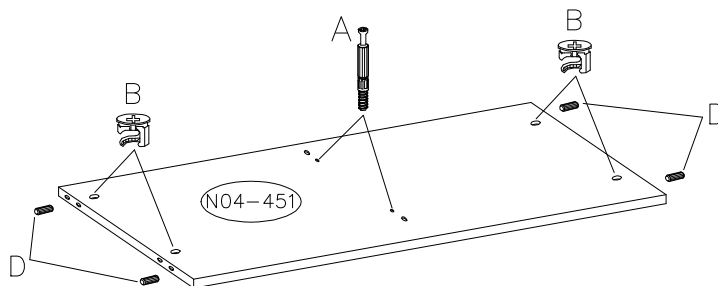
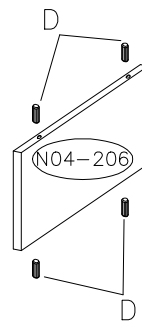
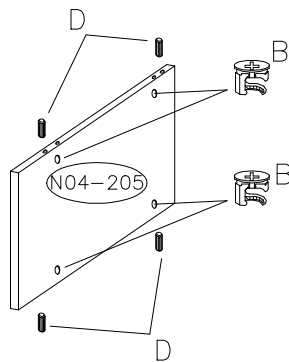
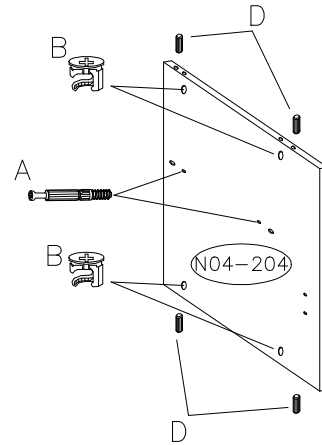
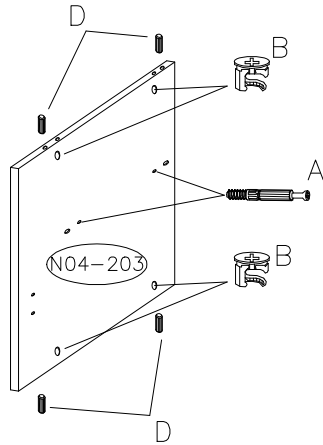
 B
16
8.0x30
 D
20
 A
6

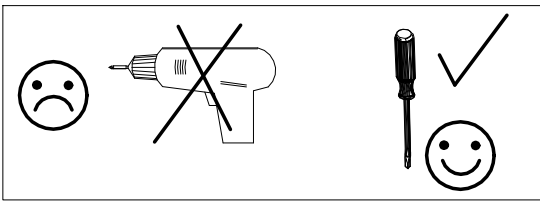

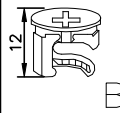

 12 B	 A2
4	2

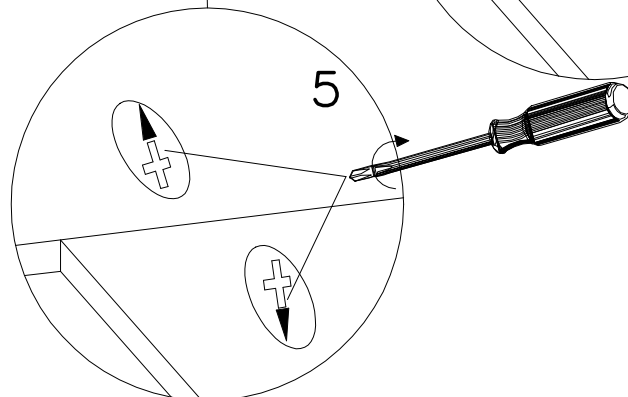
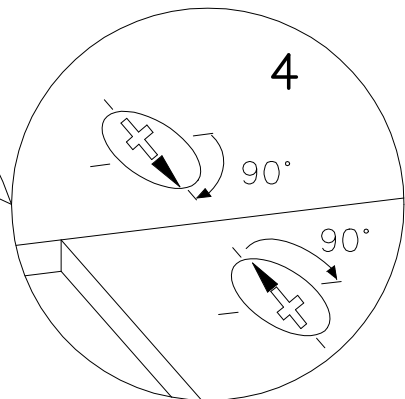
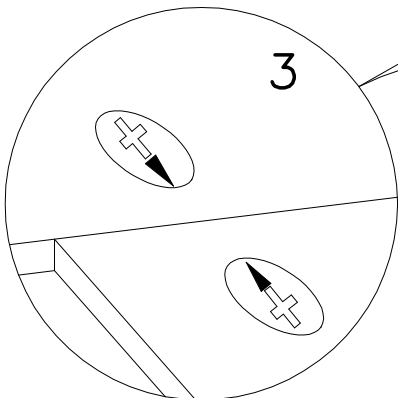
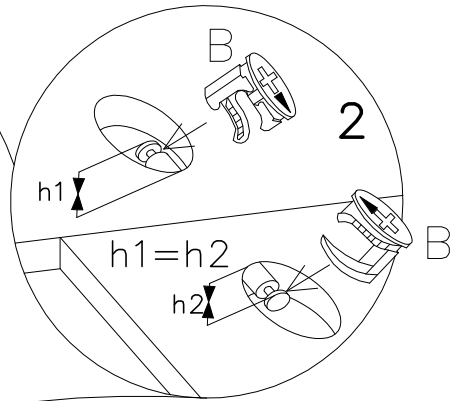
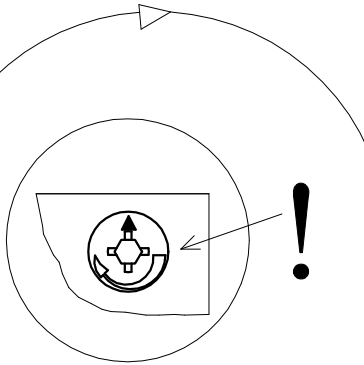
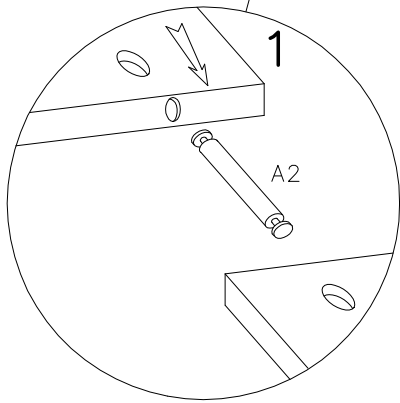
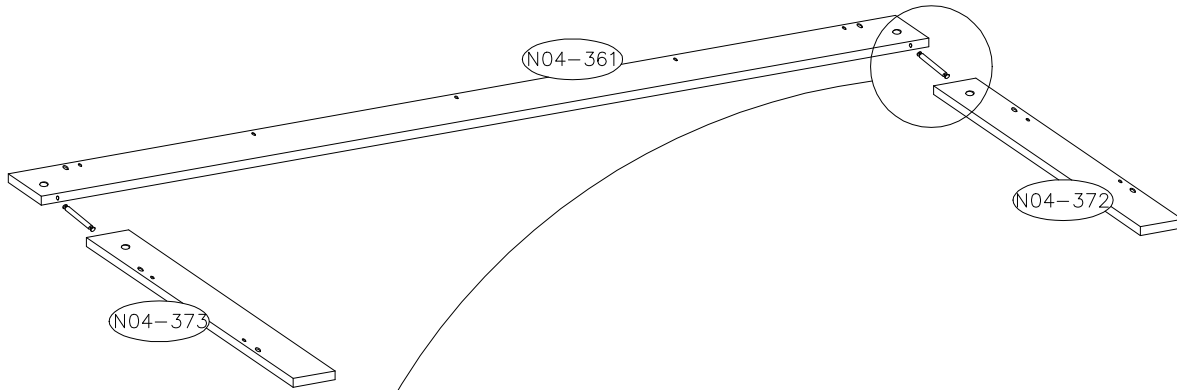

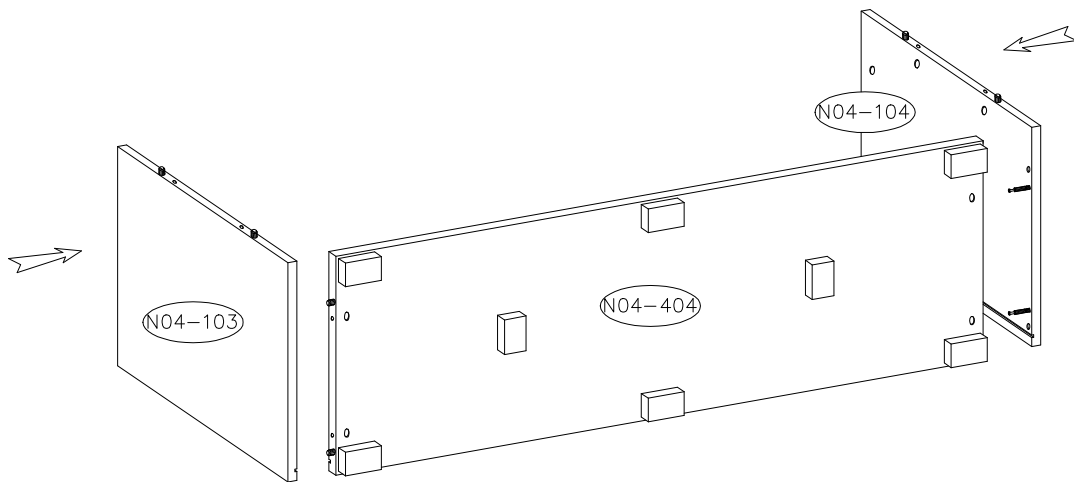
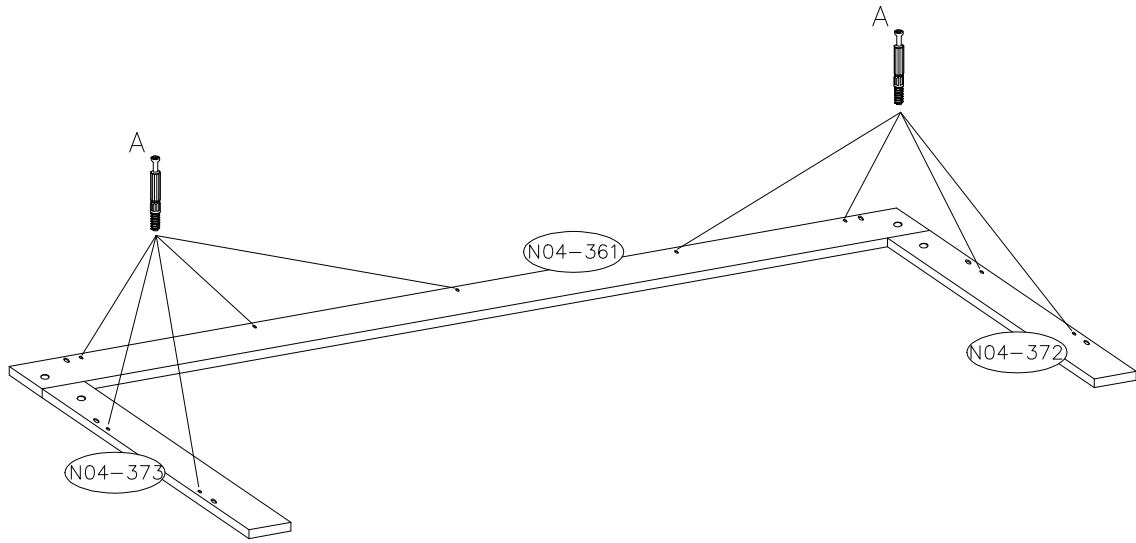
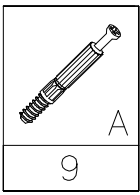



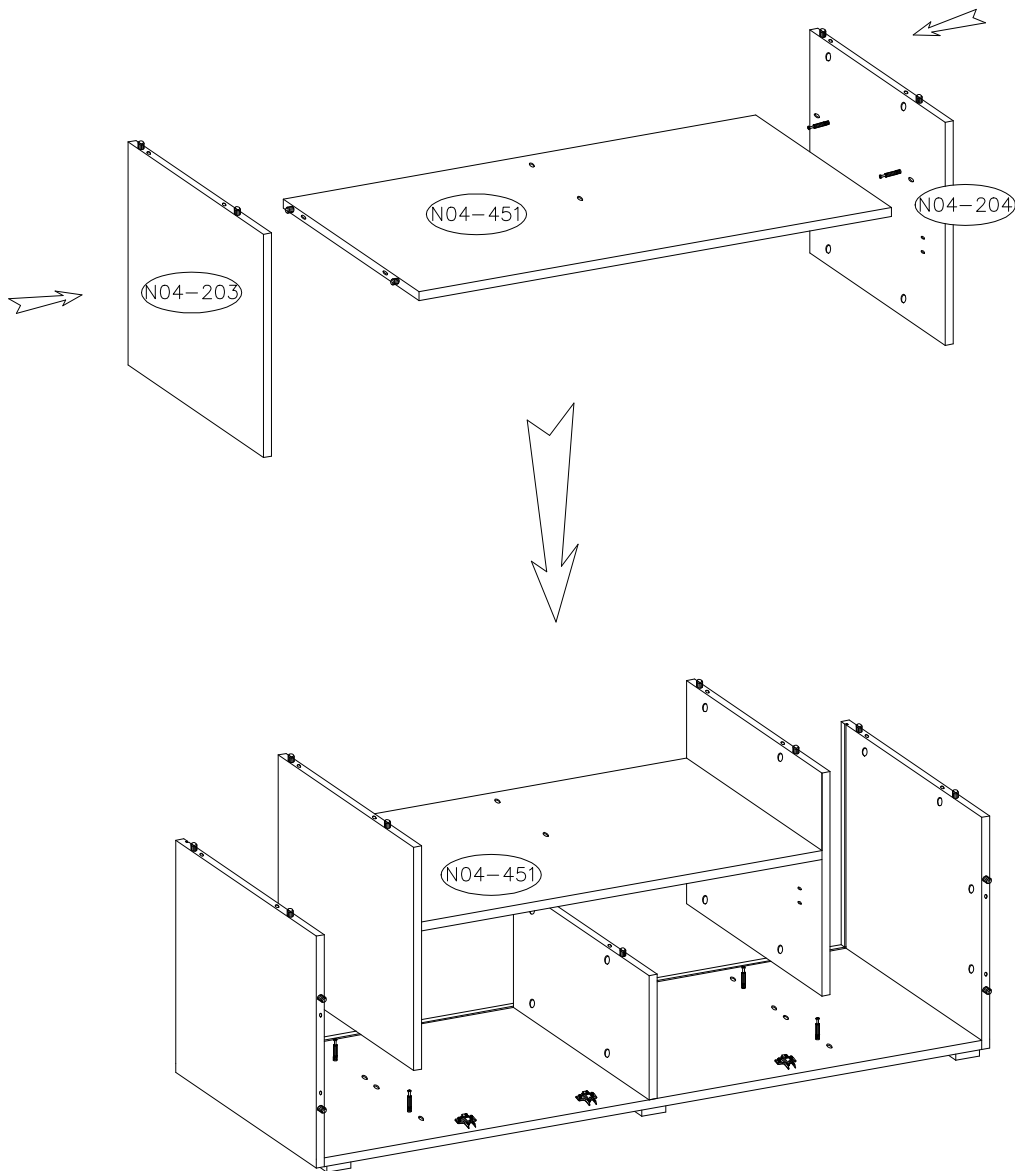
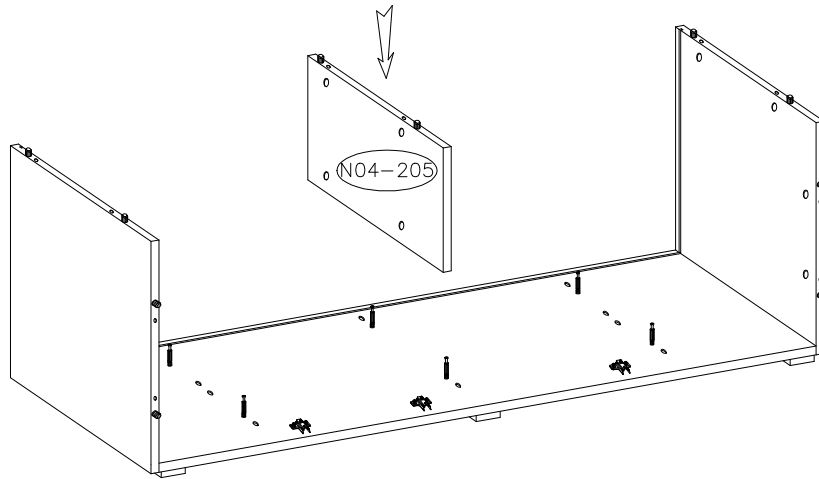

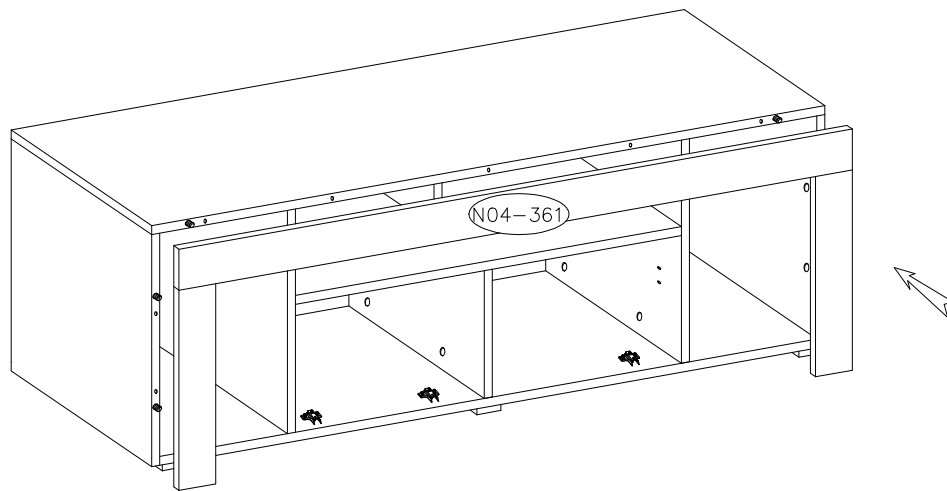
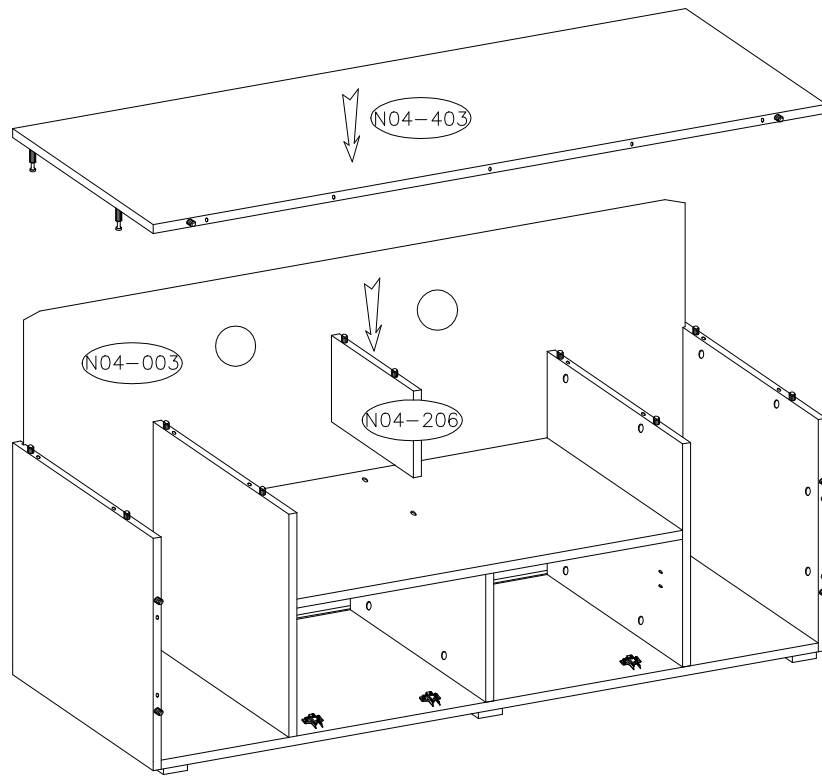

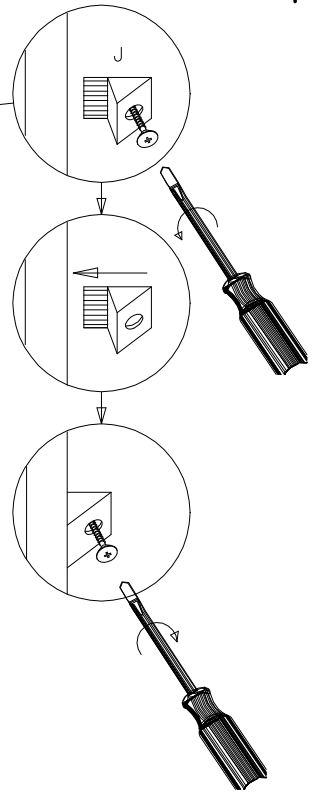
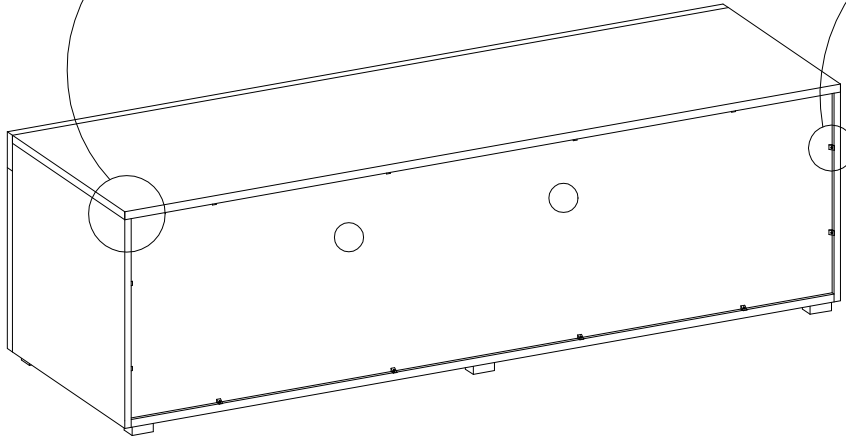
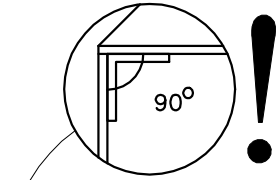
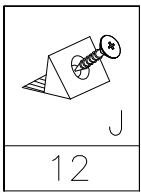





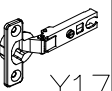
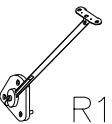

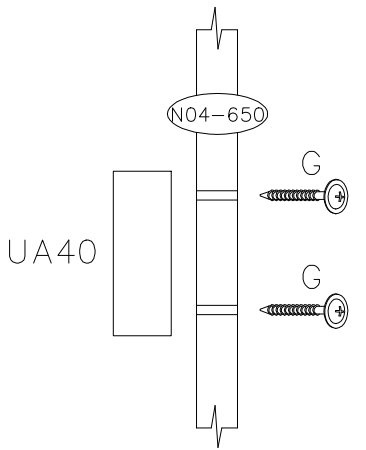
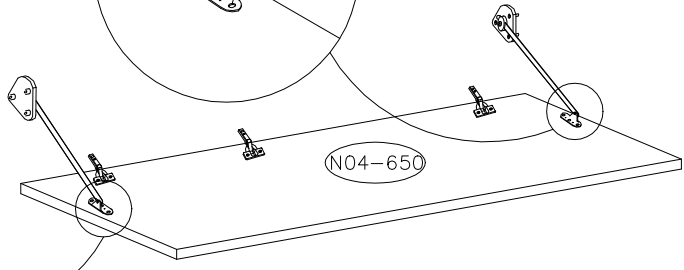
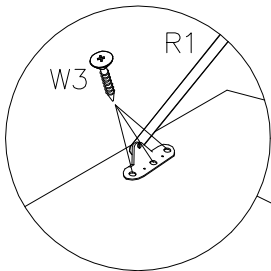
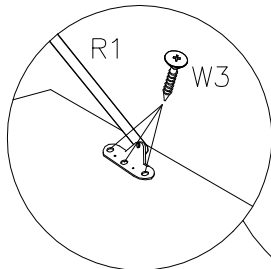
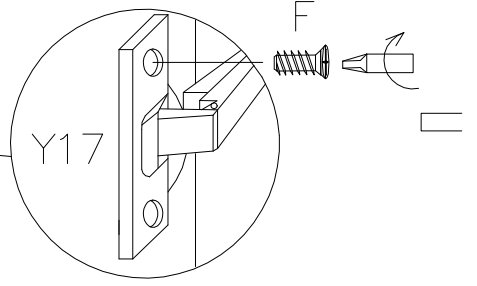
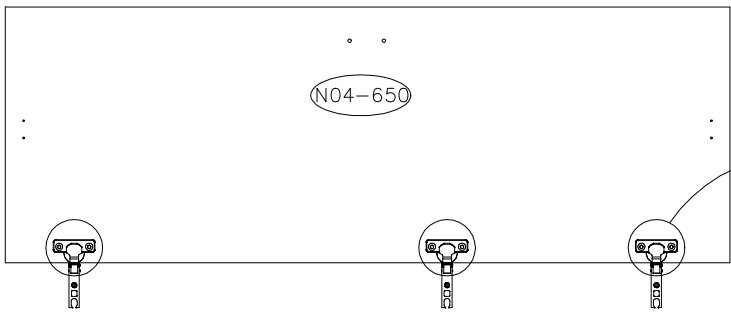
6.3x13  F 6	3.0x13  W3 6	4.0x25  G 2	L-62  UA40 1	KR-0  Y17 3	 R1 2
--------------------------------------------------------------------------------------------------------	---------------------------------------------------------------------------------------------------------	--------------------------------------------------------------------------------------------------------	---------------------------------------------------------------------------------------------------------	--------------------------------------------------------------------------------------------------------	-----------------------------------------------------------------------------------------------



3.0x13  W3	 C1
6	29

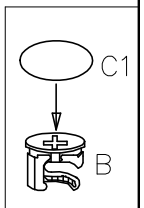
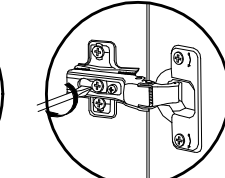
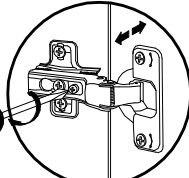
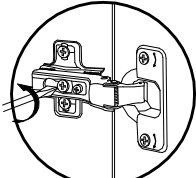
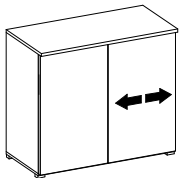
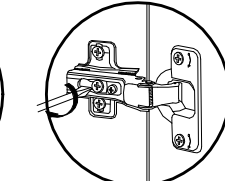
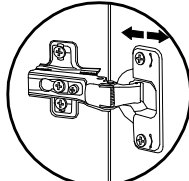
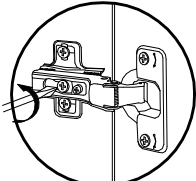
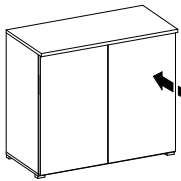
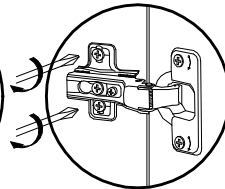
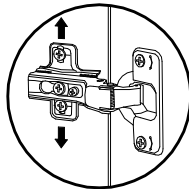
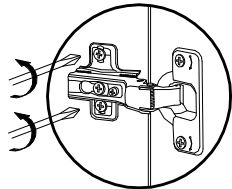
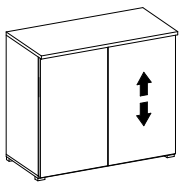
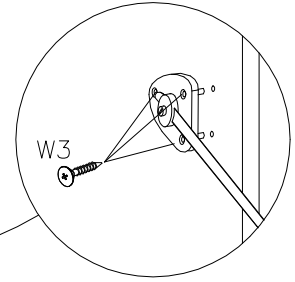
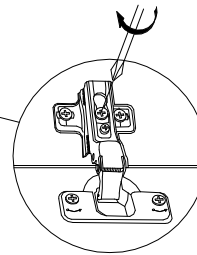
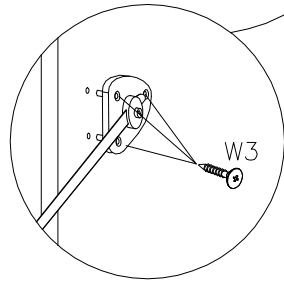
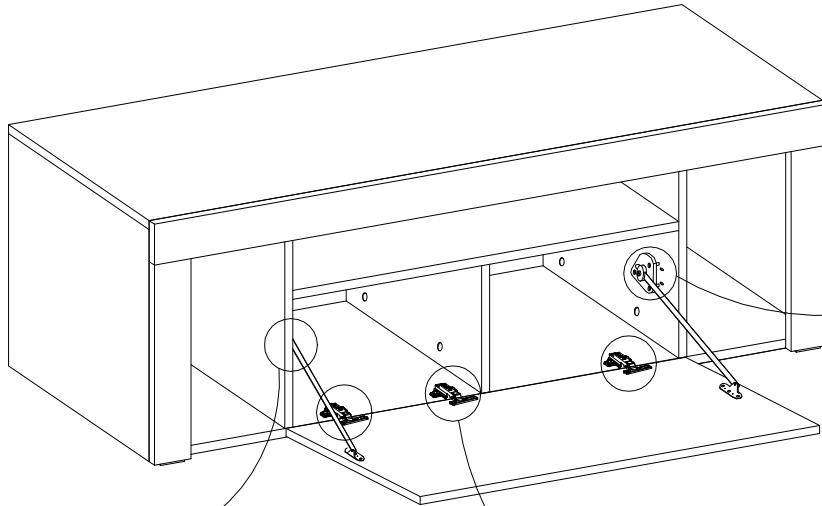

- F** Mettre la porte (égaler les gonds)
- I** Regolare la porta (livellare le parentesi)
- D** Turen einstellen (Scharniere justieren)
- GB** Adjusting the doors (adjusting the hinges)
- NL** Deuren instellen (scharnieren afstellen)
- PL** Nastawic drzwi (wyrównac zawiasy)
- TR** Kapıların ayarlanması (menteselerin seviye ayarı)
- RU** Регулировка дверей (регулировка шарнира)
- RO** Ajustați ușa (alineați balamalele)
- CZ** Seříd'te dveře (vyrównejte závěsy)
- SK** Zrad'te dvere (vyrównajte závesy)
- HU** Állítsa be az ajtót (igazítsa be a zsanérokat)

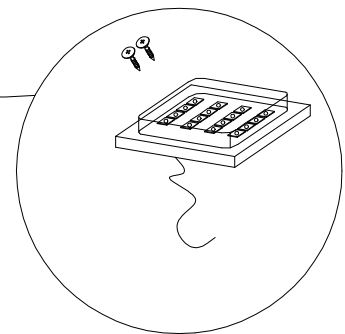
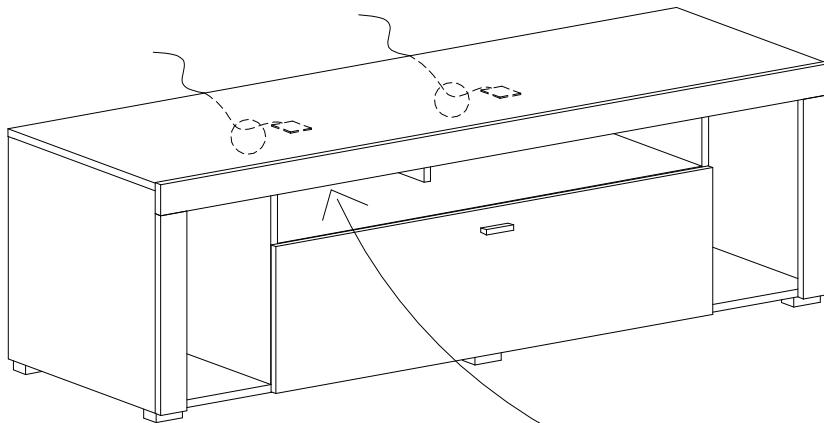
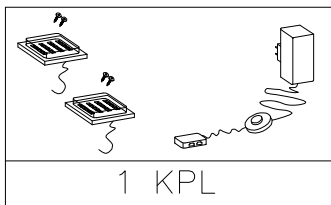

- Ⓐ **PL Uwaga: Punkty mocowania opcjonalnego oświetlenia**
- Ⓒ **CZ Upozornění: body k připevnění doplňkového osvětlení**
- Ⓓ **D Hinweis: Befestigungspunkte für optionale Beleuchtung**
- Ⓔ **GB N.B.: Fixing points for optional lighting**
- Ⓕ **F Remarque: Points de fixation de l'éclairage optionnel**
- Ⓖ **HU Figyelem: Opcionális világítás rögzítési pontjai**
- Ⓘ **I NOTA: punti di fissaggio opzionale dell'illuminazione**
- Ⓝ **NL OPGELET: Optionele bevestigingspunten van de verlichting.**
- Ⓡ **RU ВНИМАНИЕ: Точки крепления дополнительного освещения**
- Ⓡ **RO Atenție: Punctele opționale de fixare a iluminatului**
- Ⓢ **SK Upozornenie: body k pripevnení dodatočného osvetlení**
- Ⓣ **TR Dikkat: Seçenekli aydınlatmanın yerleştirilmesinin noktaları**

(PL) Instrukcja montażu

(CZ) Návod k montáži

(D) Montageanleitung

(GB) Assembly instruction

(F) Model d'emploi

(HU) Szerelési útmutató

(I) Istruzione di montaggio

(NL) Handleiding voor de montage

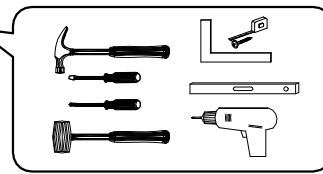
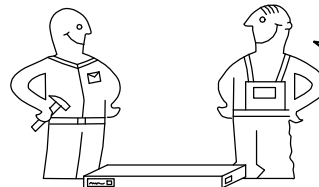

(RU) Инструкция по монтажу

(RO) Instrucțiuni de montare

(SK) Návod k montáži

(TR) Montaj talimatı

⚠ <b>Uwaga • Upozornění • Achtung • Attention • Caution • Figyelem</b> <b>Attenzione • Opgelet • Внимание • Atenție • Upozornenie • Dikkat</b> ⚠	
PL	Czyszczenie należy wykonać wyłącznie za pomocą ściereczki lub lekko nawilżonego ręcznika. Nie stosować środków czyszczących do szorowania.
CZ	Čistění je nutné vykonávat výhradně pomocí utěrky nebo lehce navlhčeného ručníku. Nepoužívejte čisticí prostředky obsahující abrazivní částice.
D	Bitte nur mit einem Staubtuch oder leicht feuchtem Lappen reinigen. Keine scheuernden Putzmittel verwenden.
GB	Please only clean with a duster or a damp cloth. Do not use any abrasive cleaners.
F	Le nettoyage se fait uniquement à l'aide d'un torchon ou d'une serviette légèrement mouillée.
HU	A tisztítás kizárólag törülőruha vagy enyhén nedvestett törölköző segítségével végezhető. Súroló hatású tisztítószereket nem szabad használni.
I	Pulire esclusivamente con un panno o un asciugamano umido.
NL	Reinig alleen met een stofdoek of een lichtjes vochtige doek. Gebruik geen schurende poetsmiddelen.
RU	Очищайте от пыли тряпкой или слегка влажной ветошью. Не допускается применение чистящих средств, не пред-назначенных для ухода за мебелью.
RO	Curățarea trebuie efectuată numai cu o cârpă sau cu un prosop ușor umezit. Nu utilizați agenți de curățare abrazivi.
SK	Čistení je nutné vykonávať výhradne pomocou utierky alebo ľahko zvlhnutým ručníkom. Nepoužívajte čistiace prostriedky obsahujúce abrazívne častice.
TR	Lütfen sadece bir toz bezilye veya hafif nemli yumuşak bir bezle siliniz. Aşındırıcı temizlik malzemeleri kullanmayınız.

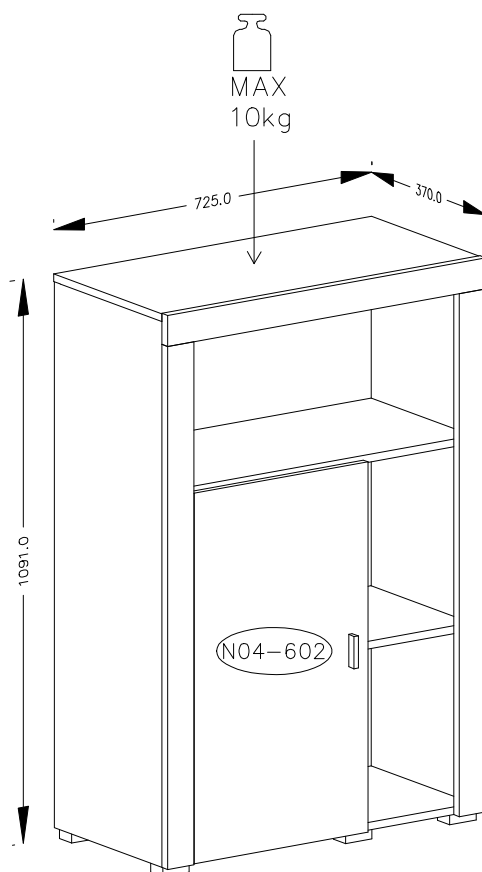
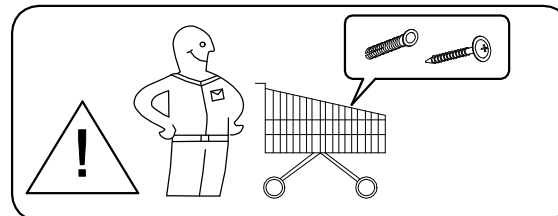
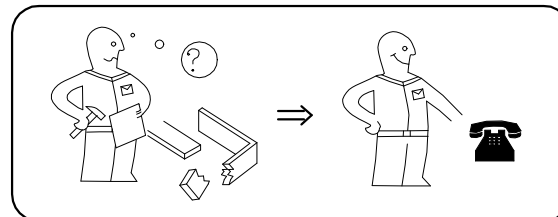
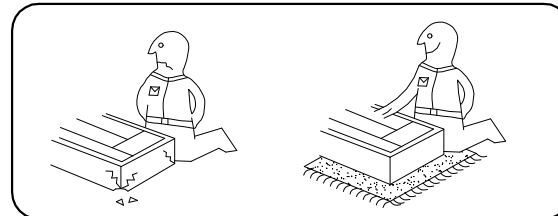

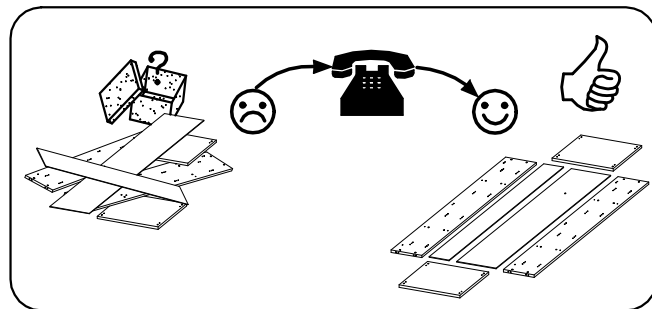
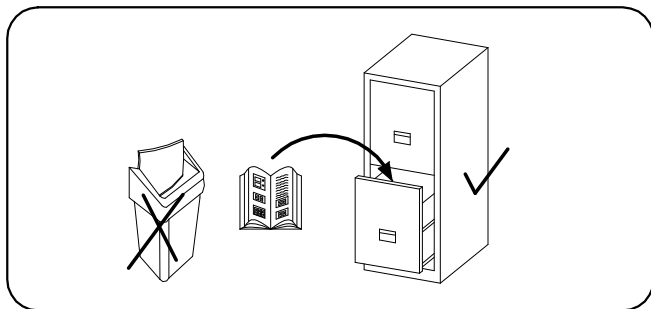



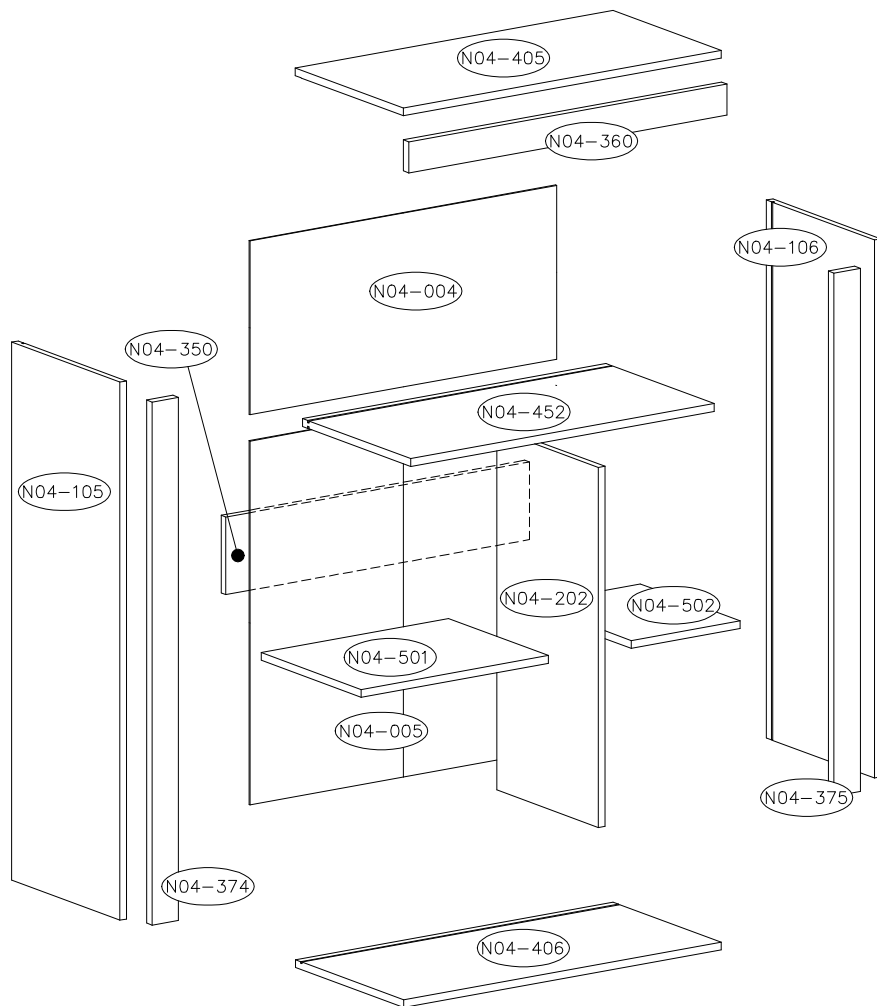

MAX  
5kg

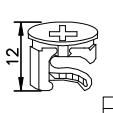
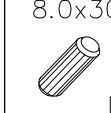
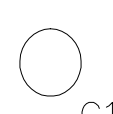
N04-452 N04-501 N04-502

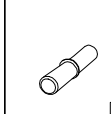
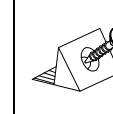
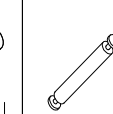
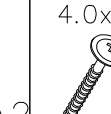
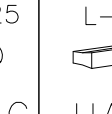
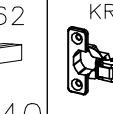
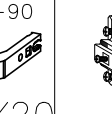
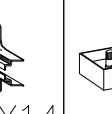
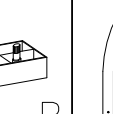

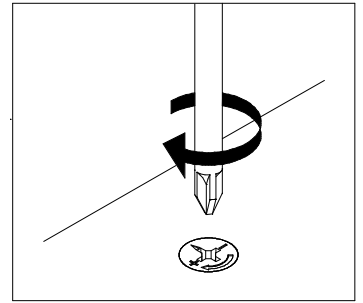
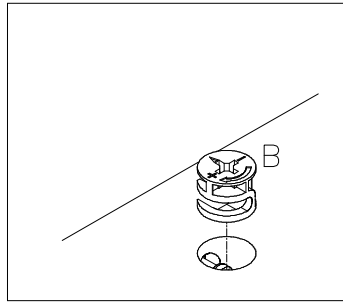
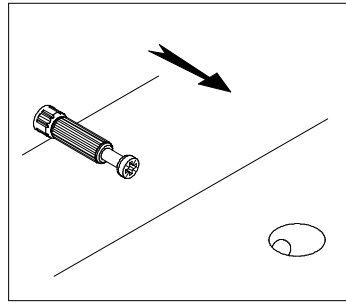
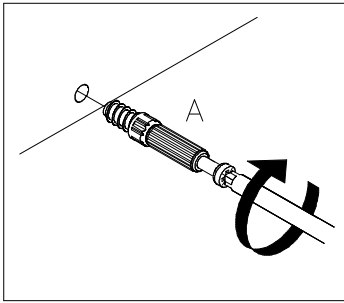
 A	 B	 D								
27	31	26								
 C1	 F	 E	 J	 A2	 G	 UA40	 Y20	 X14	 P	 J2
22	4	8	14	2	2	1	2	2	6	1

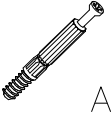
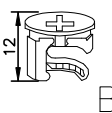

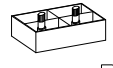

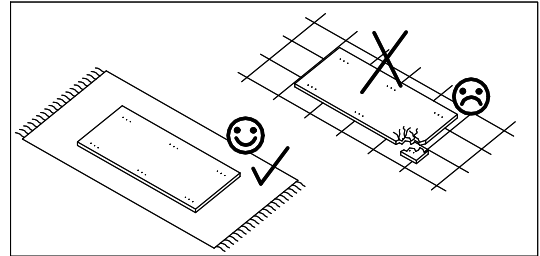
			
A	B	D	P
8	13	14	6

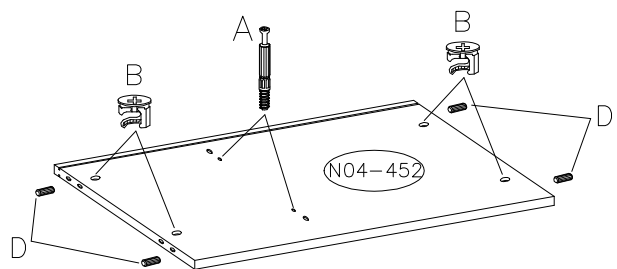
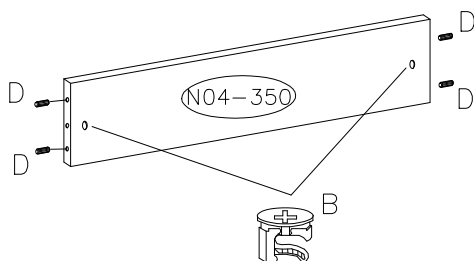
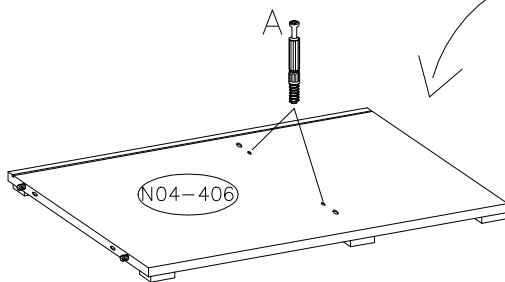
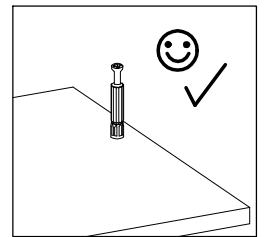
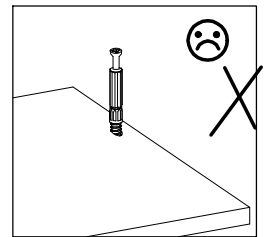
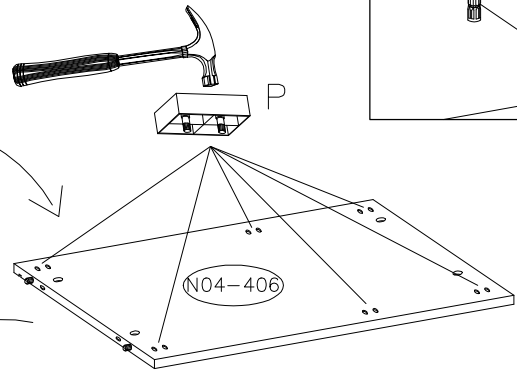
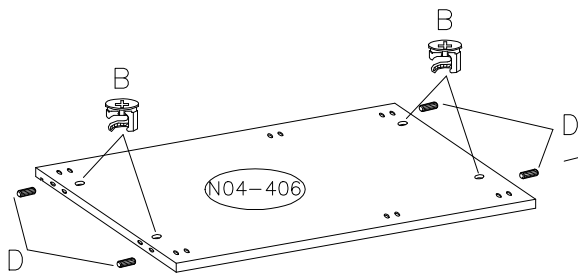
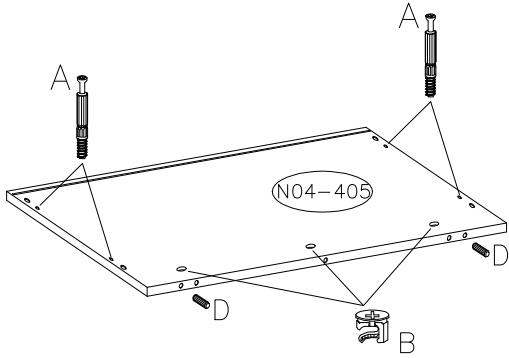

1



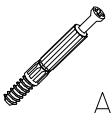
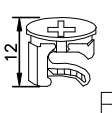

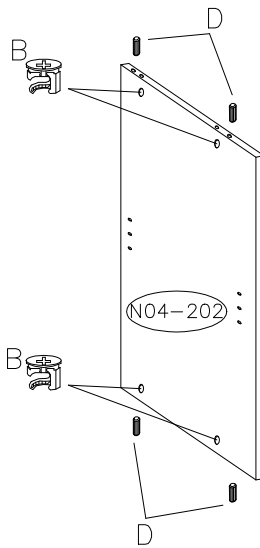
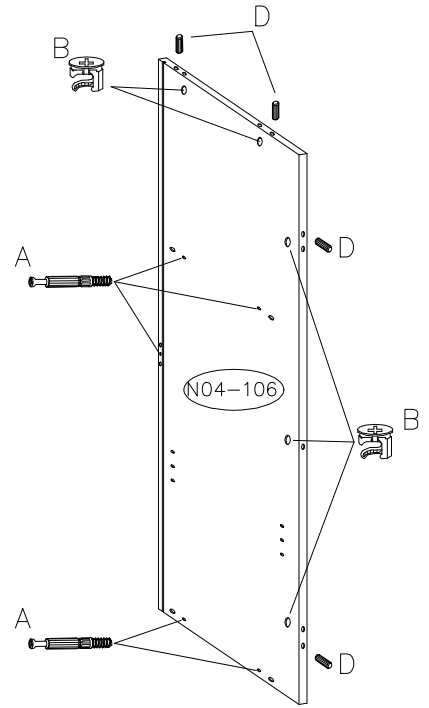
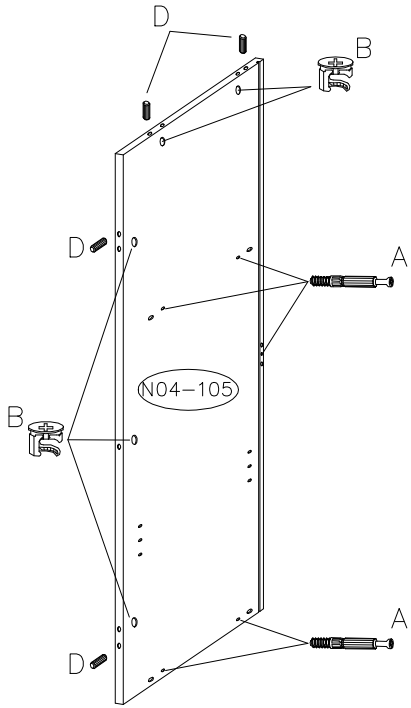

 A	 B	 8.0x30 D
10	14	12

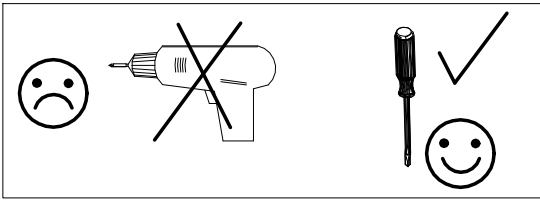

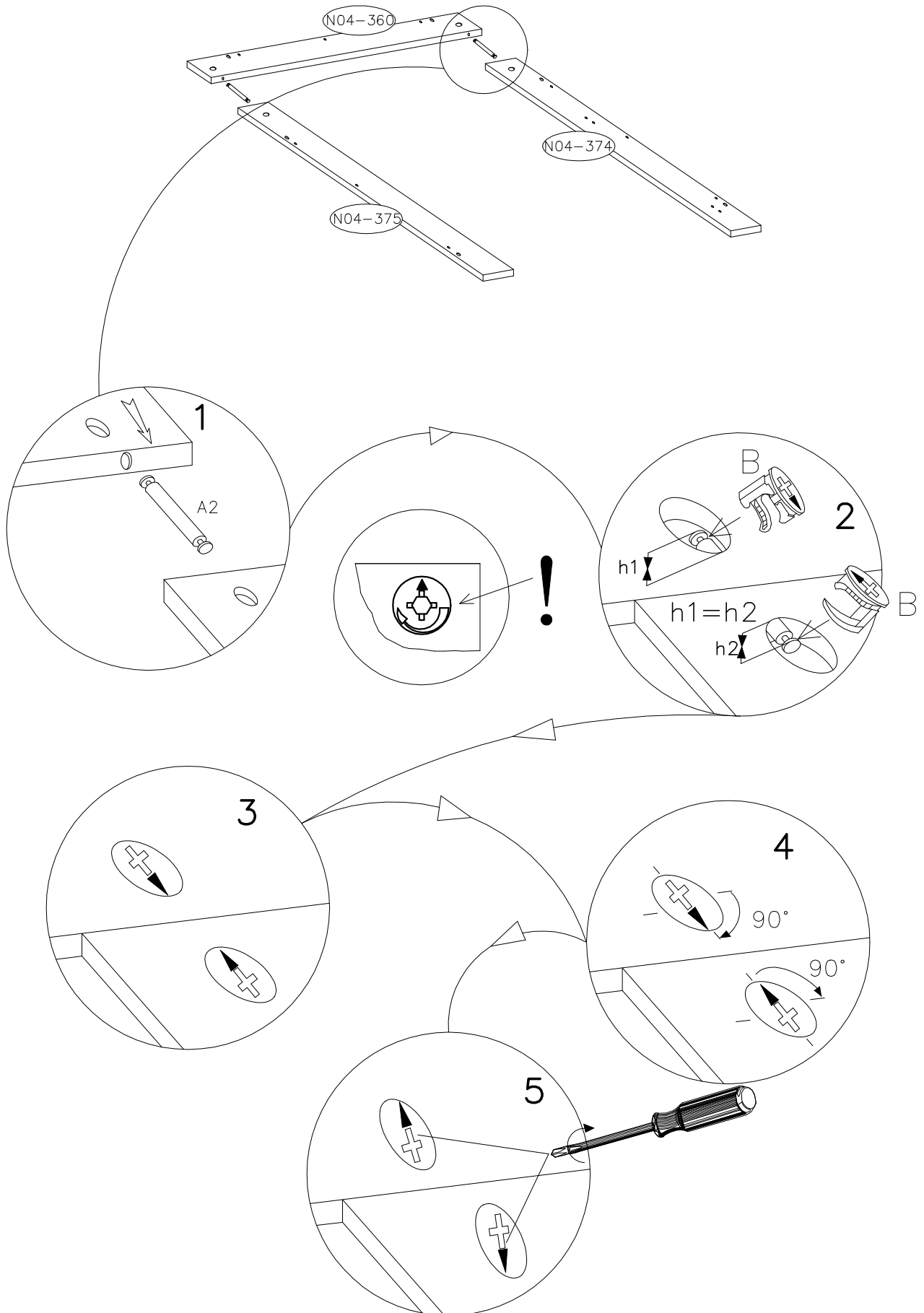

<p>12 B</p>	<p>A2</p>
4	2



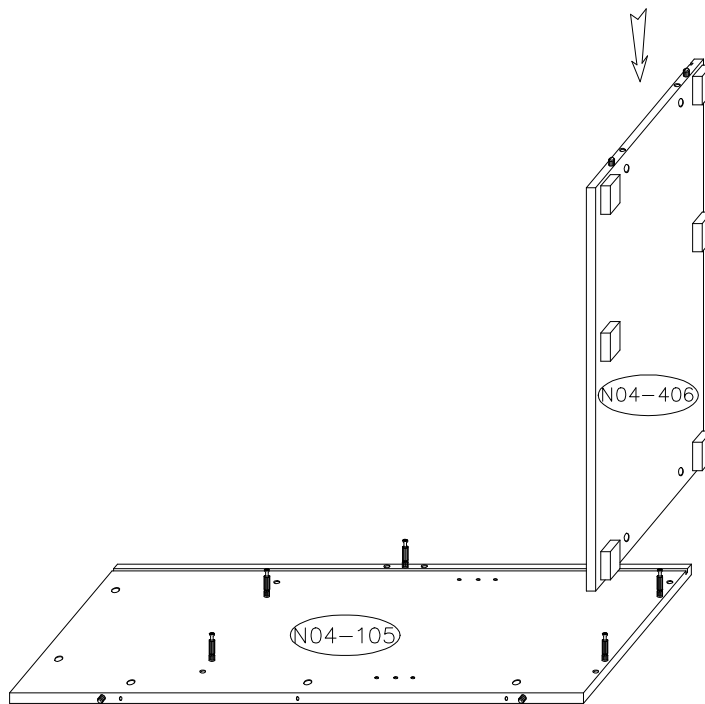
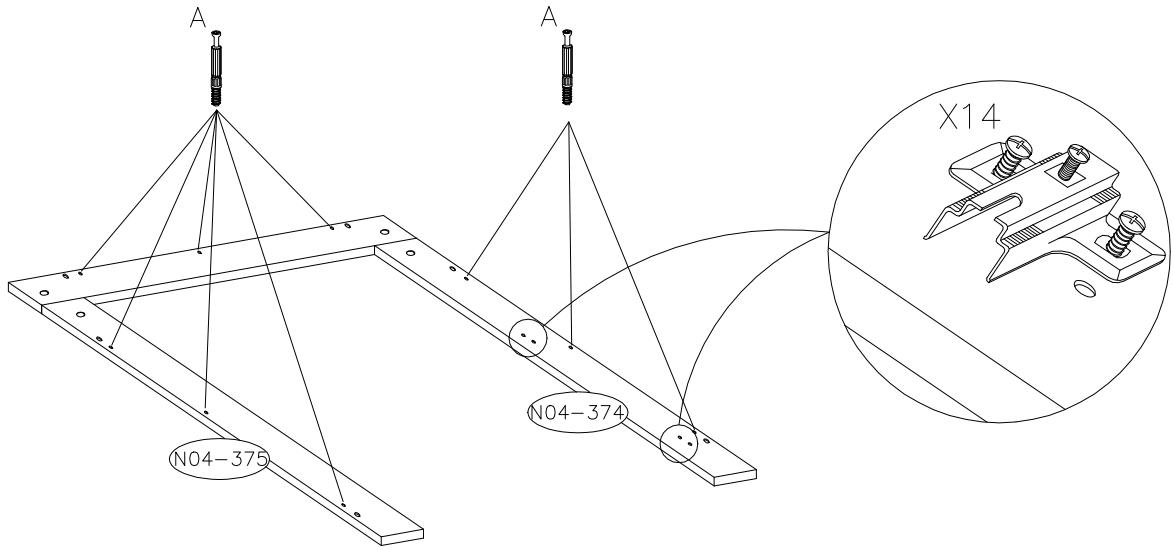

 X14	 A
2	9

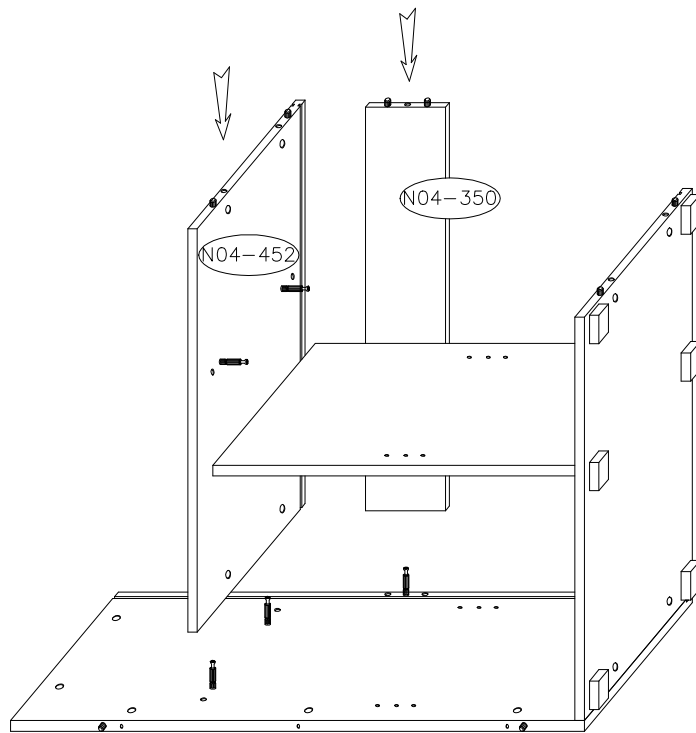
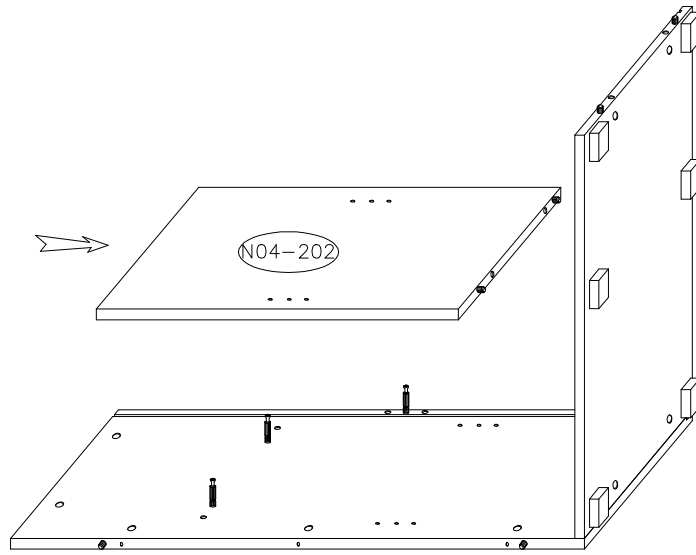

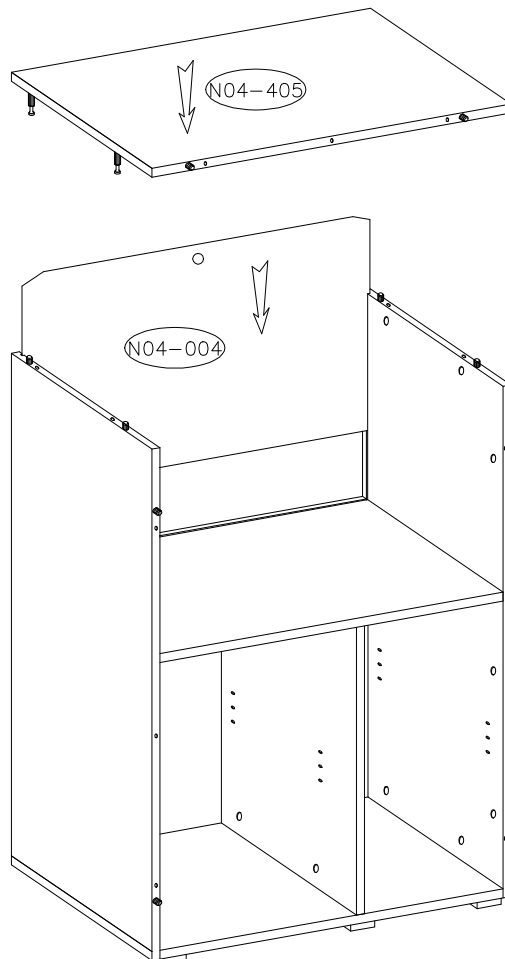
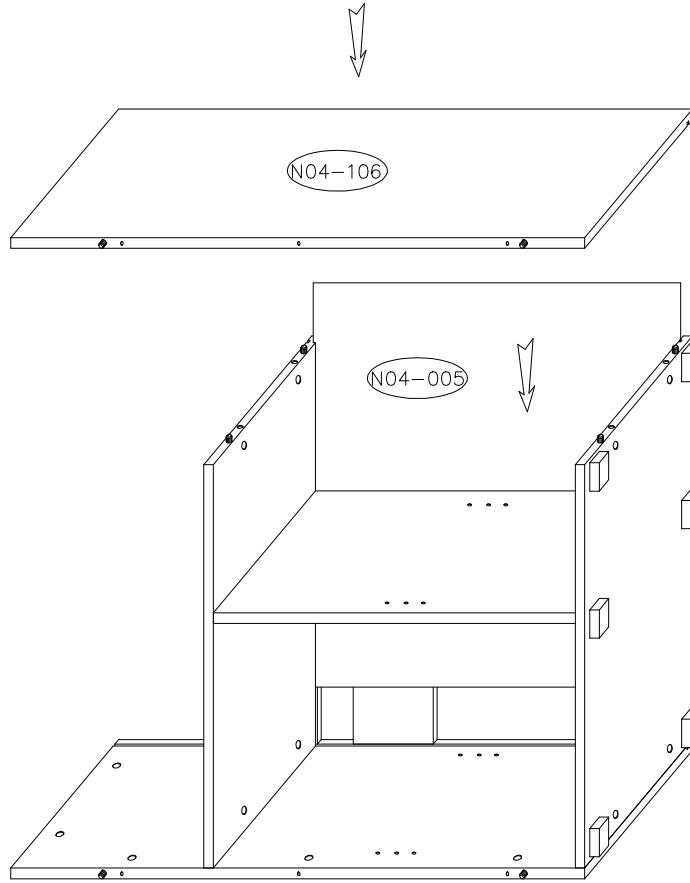

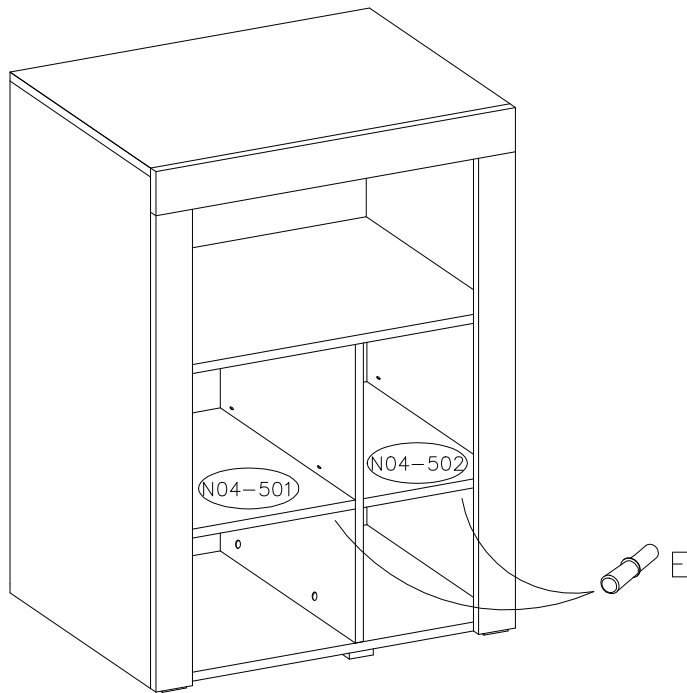
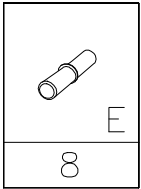
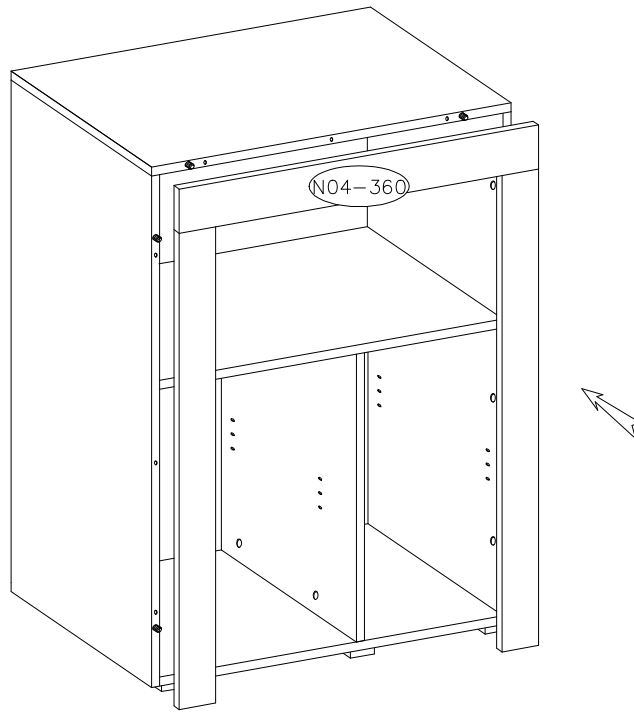



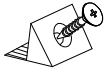

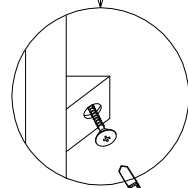
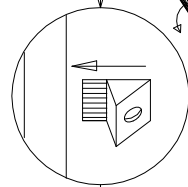
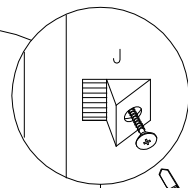
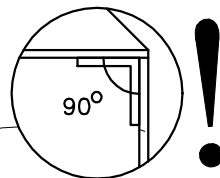
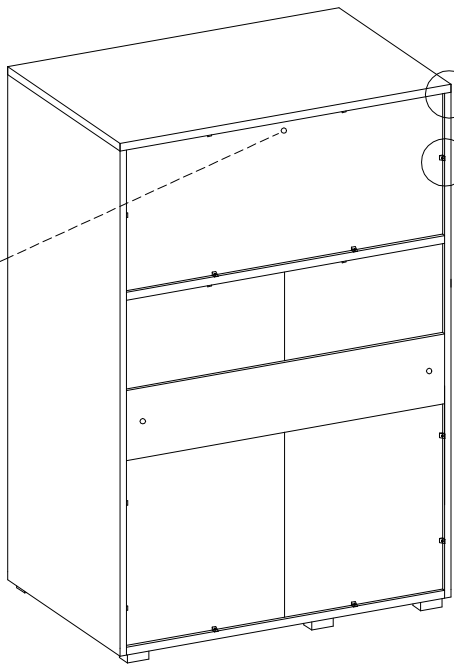

 C1 1	 J 14
---------------------------------------------------------------------------------------------	---------------------------------------------------------------------------------------------

C1 

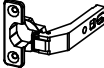

6.3x13  F 4	4.0x25  G 2	L-62  UA40 1	KR-90  Y20 2
---------------------------------------------------------------------------------------------------------	---------------------------------------------------------------------------------------------------------	----------------------------------------------------------------------------------------------------------	----------------------------------------------------------------------------------------------------------

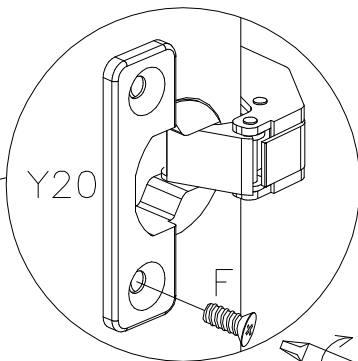
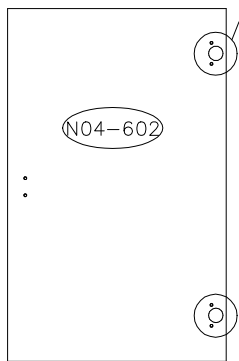

UA40

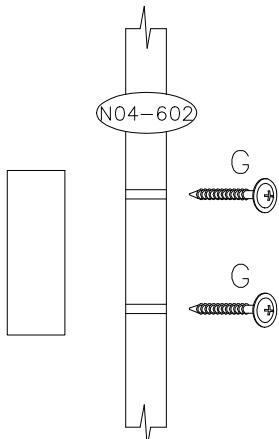

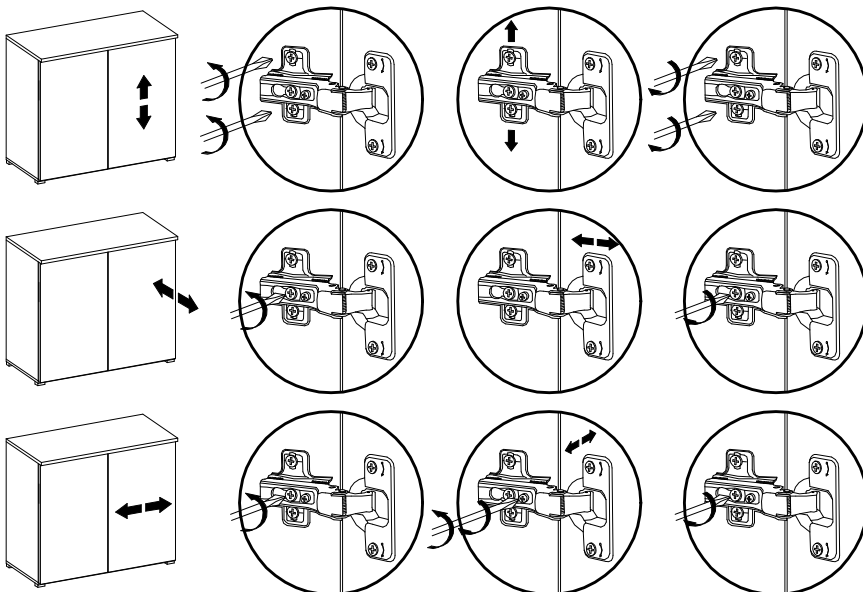
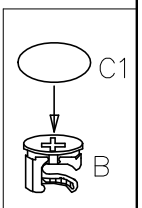
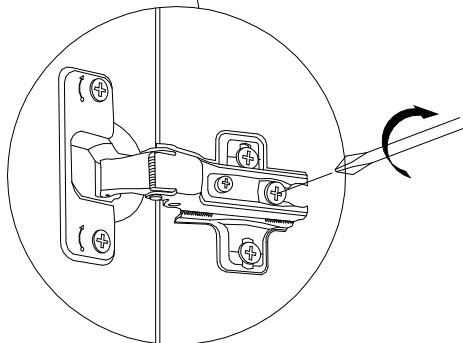
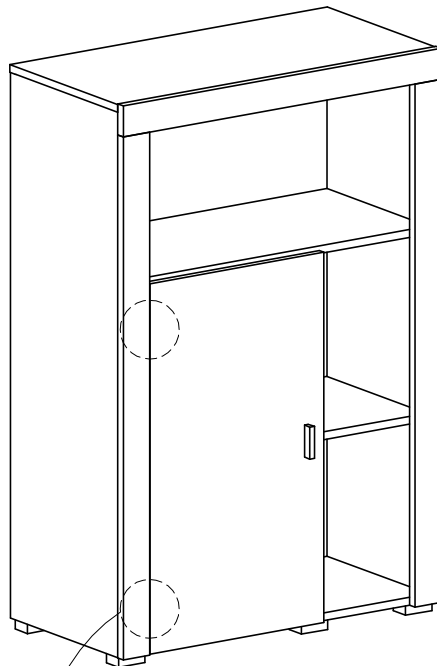
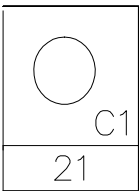

- F** Mettre la porte (égaler les gonds)
- I** Regolare la porta (livellare le parentesi)
- D** Turen einstellen (Scharniere justieren)
- GB** Adjusting the doors (adjusting the hinges)
- NL** Deuren instellen (scharnieren afstellen)
- PL** Nastawic drzwi (wyrownac zawiasy)
- TR** Kapilarin ayarlanmasi (menteşelerin seviye ayari)
- RU** Регулировка дверей (регулировка шарнира)
- RO** Ajustați ușa (aliniati balamalele)
- CZ** Seřid'te dveře (vyrovnejte závěsy)
- SK** Zrad'te dvere (vyrovnajte závesy)
- HU** Állítsa be az ajtót (igazítsa be a zsanérokot)



1

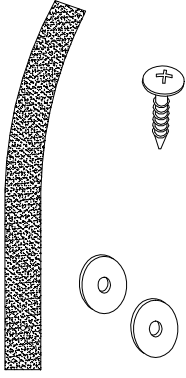

<b>Uwaga • Upozornini • Achtung • Attention • Caution • Figyelem</b> <b>Attenzione • Opgelet • Внимание • Atentie • Upozornenie • Dikkat</b>	
PL	Mocowanie do ściany jest jednocześnie zabezpieczeniem przed przewróceniem – koniecznie zamontować! Do niektórych rodzajów ścian koniecznie zastosować specjalne kołki mocujące. Montaż na ścianie służy jako ochrona przed przewrnięciem – bezpodmiennie umieścić! U niektórych typów ścian może być potrzebny specjalny hmoždinka!
CZ	U některých typů stěn může být zapotřebí speciální hmoždinka!
D	Wandbefestigung dient als Kippschutz – unbedingt anbringen! Bei einigen Wandtypen kann ein Spezialdübel erforderlich sein!
GB	The wall fastening serves to prevent tipping – be absolutely sure to mount it! For certain wall types, a special wall plug may be necessary!
FR	La fixation murale sert de protection contre le basculement – à installer impérativement ! Pour certains types de murs il faut des chevilles spéciales !
NL	Bevestiging aan de muur dient als kantelbescherming – zeker en vast bevestigen! Bij enkele muurtypes is een speciale plug misschien vereist!
IT	Il fissaggio alla parete serve da protezione anti-ribaltamento – attaccarlo assolutamente! Per alcune strutture di parete può essere necessario un tassello speciale!
HU	A termékét a falhoz kel rögzíténi, különben az felborulhat! Egyes faltípusoknál speciális tiplit kell használni!
RU	Обязательно установите крепление на стене во избежание опрокидывания! Для некоторых типов стен может потребоваться специальная дюбель!
RO	Sistemul de fixare la perete serve ca protecție la răsturnare – de montat obligatoriu! Pentru unele tipuri de pereți este posibil să fie necesar un diblu special!
SK	Upevnenie na stenu slúži ako ochrana proti prevráteniu – bezpodmienečne použiť! Pre niektoré druhy stien môže byť potrebná špeciálna hmoždinka!
TR	Duvardaki sabitleme, devrilmeye karşı bir emniyet tedbiridir ve mutlaka monte edilmelidir! Bazı duvar tiplerinde bunun için özel bir dübel gerekli olabilir!

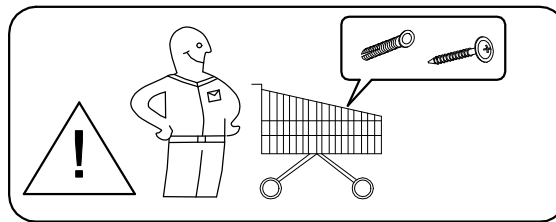
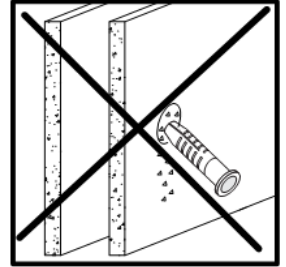
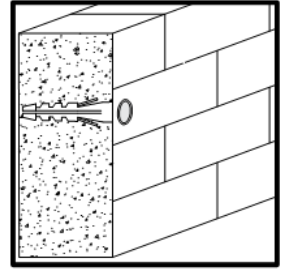

2a

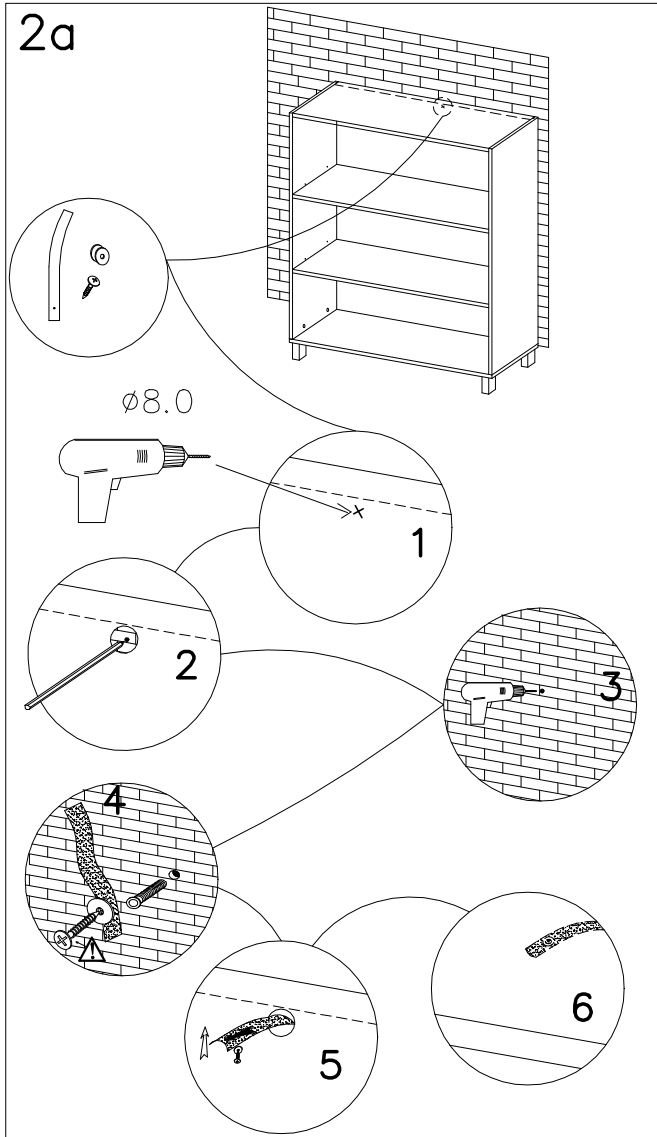

2b

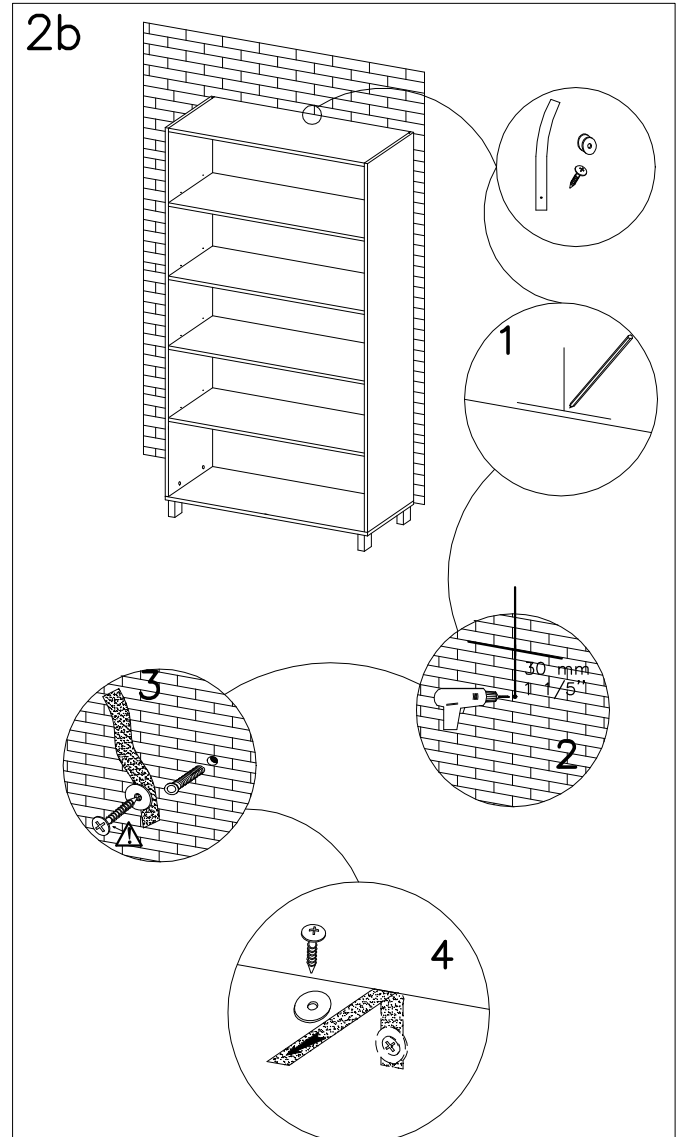

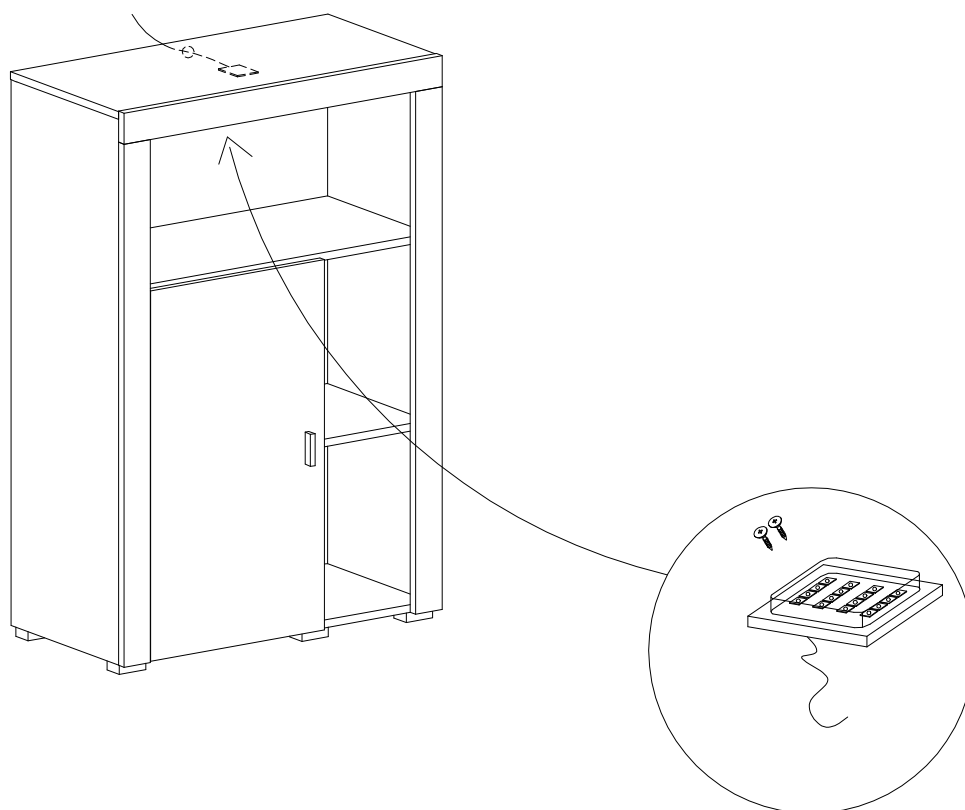
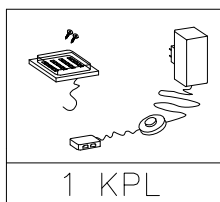

- Ⓐ **Uwaga: Punkty mocowania opcjonalnego oświetlenia**
- Ⓒ **Upozornění: body k připevnění doplňkového osvětlení**
- Ⓓ **Hinweis: Befestigungspunkte für optionale Beleuchtung**
- Ⓔ **N.B.: Fixing points for optional lighting**
- Ⓕ **Remarque: Points de fixation de l'éclairage optionnel**
- Ⓖ **Figyelem: Opcionális világítás rögzítési pontjai**
- Ⓘ **NOTA: punti di fissaggio opzionale dell'illuminazione**
- Ⓝ **OPGELET: Optionele bevestigingspunten van de verlichting.**
- Ⓡ **ВНИМАНИЕ: Точки крепления дополнительного освещения**
- Ⓡ **Atenție: Punctele opționale de fixare a iluminatului**
- Ⓢ **Upozornenie: body k připevnění dodatočného osvetlení**
- Ⓣ **Dikkat: Seçenekli aydınlatmanın yerleştirilmesinin noktaları**